

Investigation Report

Identification

Type of Occurrence:	Accident
Date:	8 May 2009
Location:	Frankfurt/Main
Aircraft:	Airplane
Manufacturer / Model:	The Boeing Company / B 747-400 F
Injuries to Persons:	None
Damage:	Aircraft severely damaged
Other Damage:	None
State File Number:	BFU AX001-09

Factual Information

During the approach to Frankfurt/Main parts of the left wing inboard fore flap separated and damaged the pressurised fuselage.

History of the Flight

At 2159 hrs¹ the freighter was on final approach to Frankfurt/Main Airport. It was on a flight from Vienna, Austria. Three persons were on board: two pilots, flying the airplane, one substitute pilot seated in the jump seat at the rear of the cockpit.

At the time of the occurrence the Pilot in Command (PIC) in the left-hand seat was Pilot Flying (PF). The approach to runway 25L was conducted with engaged autopilot.

¹ All times local, unless otherwise stated.

According to the Flight Data Recorder (FDR) data the flap was put in position 30° at 1,400 ft AMSL in the area of the outer marker to runway 25L. At that time Indicated Air Speed (IAS) was 160 kt. Shortly after moving the flap lever the crew heard the sound of a blow and noticed vibrations. The airplane rolled left about its longitudinal axis by approximately 1°. The autopilot counterbalanced the bank angle and the approach was continued. The landing occurred without further incident on runway 25L. The airplane taxied to the parking position.

Personnel Information

The 46-year-old PIC held an Airline Transport Pilot's License (ATPL) with the commensurate class and type ratings issued by the South-Korean aeronautical authority. He had a total flying experience of 11,000 hours; 3,600 hours of which on Boeing B 747-400.

The 40-year-old co-pilot held an Airline Transport Pilot's License (ATPL) with the commensurate class and type ratings issued by the South-Korean aeronautical authority. He had a total flying experience of 7,000 hours; of which 1,700 hours were on Boeing B 747-400.

Aircraft Information

The B 747-400 manufactured by The Boeing Company was a freight transport aircraft. The airplane was powered by four General Electric CF6-80C2B1F jet engines. According to the certificate of registration maximum take-off mass was 394,632 kg and maximum landing mass 302,098 kg. The aircraft with the manufacturer's serial number 25781 was built in 1994. Total operating time of the aircraft was 72,700 hours and 12,296 cycles.

The aircraft was registered in the Republic of Korea and operated by a South-Korean operator.

Meteorological Information

According to the airport, at the time of the occurrence it was night with visual meteorological conditions. Ground visibility was more than 10 km. Wind velocity was 250°, 7 knots.

Aids to Navigation

The Instrument Landing System (ILS) for runway 25L was used for the approach.

Aerodrome Information

Frankfurt/Main Airport had three runways. Two runways had the orientation 070°/270° (07L/25R and 07R/25L) and were 4,000 m long and 45 m and 60 m wide, respectively. A third runway had the direction 180° (18) and was also 4,000 m long and 45 m wide.

Flight Recorder

FDR and Cockpit Voice Recorder (CVR) recordings were read-out and analysed at the BFU avionics laboratory. The FDR was a Honeywell SSFDR. The CVR was a L3 A 200 S with a recording time of two hours.

Findings at the Aircraft

On the airplane part of the left wing inboard fore flap (approximately 4.5 x 1 m) was missing. The fracture had occurred approximately half a metre left of the inner flap attach fitting (Appendices Image 1). The remaining flap part was twisted around the attach fitting point and jammed between fitting and fuselage (Image 2). Two fore-flap tracks between the front and middle flap had fractured or been torn out.

The airplane's left outer fuselage skin was dented and punctured on a length of 3.5 m in the area between the fairing run-out and the aft cargo door. The frames and ribs in this area showed severe damages; the skin of the pressurised fuselage was punctured (Images 3 and 4).

Another puncture site was found on the left side of the vertical tail (Image 5).

On 12 December 2009 the police helicopter squadron Hessen found the fractured flap part in the Frankfurt Stadtwald (forest) east of the approach area of runway 25L (Image 6). The flap part was transported to the BFU for further investigation. The fractured outer attach fitting of the left wing inboard fore flap was removed (Images 7 to 9). The attach fitting had the Part Number "Assy 65B39025-2" (Image 10).

Further examination at the BFU showed that an aluminium alloy was used for the manufacture of the fractured flap attach fitting. On one side it had been screwed to

the flap spar. The bearing seat in form of a ball joint was located at the other end. A steel ball, through which a retaining bolt was guided, rested in a bronze bushing. The side without lap was flared so that the bushing remained firmly in the eye and could not be pressed out. The bushing's outer side showed a circumferential groove which was connected with the bearing seat on the inside of the bushing with three drill holes. The ball was supplied with lubrication via the groove and drill holes. A fitting on the outside which was connected with the inside via a drill in the area of the groove, guided the lubricant inside.

A bolt, which led through the drill hole to the ball, connected the attach fitting with the carriage, which moved the flap.

The fracture surfaces were examined at the Technische Universität Braunschweig, Institut für Werkstoffe (ifw) and Institut für Füge- und Schweißtechnik (ifs). Macroscopic examination revealed an extended characteristic thumbnail fatigue crack; additional smaller fatigue cracks were found on the side. The crack starting points had later been mechanically damaged and therefore could no longer be analysed. The fretting oxidation characteristic for aluminium alloys had formed on the starting points of the cracks. It was generated by the colliding of the crack flanks. The crack propagation speed increased with increased distance from the starting point. The number of flank contact per millimetre crack length decreased. Depending on the strain spectrum the contacts could be absent due to the increasing crack opening. The black fretting oxidation was then no longer generated.

The scanning electron microscope (REM) Jeol JSM-6480 confirmed the macroscopic result in full. Image 11 in the Appendix shows a plaque of oxidation coating in the starting area of the main crack. In the metallic blank area the linear striations were clearly visible (Images 12 and 13). Image 14 shows the transition to the forced residual fracture. Image 15 depicts the dimples of this microscopic ductile forced fracture area.

Due to the experiences with another occurrence, where the flap attach fitting of the same aircraft type had fractured at the same place, the inner surface, where the crack originated, was analysed again. The examination with the REM revealed that the inside of the bearing seat showed distinct corrosion areas in form of holes and depressions. These were located mostly in the "track" and often in the transition region on the edge to the "track". "Track" means the area where the bronze bearing located in the bearing seat had its lubrication groove (Images 16 and 17). This "track area" showed almost no corrosion.

The metallographic cross specimen showed heavy corrosion on the entire surface of the bearing seat. The base metal seemed to dissolve. The surfaces left and right of the “track” were much more affected than the “track area” itself. Heavy corrosion could be seen in the transition region and at the edge to the “track”. This result correlated with the REM examination. The difference in wall thickness between the “track area” and the rest of the inner surface had attracted attention. The inner surface’s wall was thinner than the one of the “track area” (Image 18). The reason was different mechanical abrasion in these areas.

Additional Information

Already in the 1970s events occurred where the outer attach fitting of the inboard trailing edge fore flap fractured or showed cracks. Back then the cause was fatigue cracks. The manufacturer described reasons for the fatigue cracks and commensurate corrective actions in the Service-Bulletin (SB) 747-57-2119 Revision 2 dated 20 June 1975. The Appendix shows an excerpt of the SB.

According to the manufacturer the flap attach fittings with the Part Number 65B39025-2 corresponded with the original design but are no longer in use. The attach fittings currently in use have the Part Number 65B39025-31/20.

Analysis

The severe damages of the airplane, especially the punctured pressurised cabin, were caused by the fracture of the left inboard trailing edge fore flap. Due to these damages the occurrence was classified as accident. The fracture of the flap was the result of the fractured outer flap attach fitting. It fractured as a result of a fatigue crack, which had propagated over time to about half of the front of the bearing seat's bar. This front bar is the area where the highest stress occurred. The residual fracture occurred as forced rupture. The starting point of the fracture could not give any indication as to the cause because it had later been mechanically damaged. Due to the corrosion found on the surface of the bearing seat, and the experiences from another case, it is highly likely that the corrosion formed depressions and holes, which provided a starting point for a fatigue crack at the area of the highest stress. Therefore, in this case it is highly likely that the corrosion of the bearing seat's surface was the real cause for the fracture of the flap attach fitting.

The SB does not mention corrosion of the bearing seat. It mentions wear, stiffness, and possible miss-alignment of the flap mechanism as potential causes for a fatigue fracture. These are surely possibilities which may increase loads and stress on the attach fitting. The BFU is of the opinion that as root cause for fatigue cracks these attempts at explanation are insufficient. A fatigue fracture can occur anywhere, where a potential starting point is encountered. In this case the corrosion provided this starting point. If the starting point is there the fatigue crack propagates in the area of the highest stress. The stress level may be lower than during dimensioning of the component. Therefore a fatigue crack can start in a corrosive environment even if the flap mechanism is well adjusted and functions properly.

The laboratory results showed that the surface condition of the bearing seat, in which the lubrication groove of the bronze bearing was located, was different from the remaining area. The "track area" was slightly elevated and clearly less sensitive to corrosion. The major part of the surface showed depression and hole corrosion. Such an area provided the kerf where a fatigue crack could start.

Conclusions

The flap attach fitting was destroyed by an extended fatigue fracture. It is highly likely that it started with a corrosion depression.

Safety Recommendations

Recommendation No 06/2018

The aircraft manufacturer, as type certificate holder of aircraft type Boeing B 747-400, should enhance the corrosion resistance of the flap attach fitting, especially in the bearing seat area.

Recommendation No 07/2018

The aircraft operator should check the flap attach fittings used in their Boeing B 747-400 aircraft pursuant to the manufacturer's revised Service Bulletin (SB) 747-27-2366R3 and Service Letter 747-SL-57-085-C and, if appropriate, replace them.

Investigator in charge:	Nehmsch
Field investigation:	Nehmsch, Kühne
Assistance:	Ritschel, Kühne

Braunschweig 29 March 2018

Appendix



Image 1: Area of the left wing, where the flap part is missing.

Source: BFU



Image 2: Jammed part of the remaining flap

Source: BFU



Image 3: Damage on the fuselage

Source: BFU



Image 4: Damage on the fuselage

Source: BFU



Image 5: Damage on the vertical tail

Source: BFU



Image 6: Located flap part

Source: Bundespolizei



Image 7: Located flap part

Source: BFU



Image 8: Fractured flap attach fitting (bearing seat)

Source: BFU

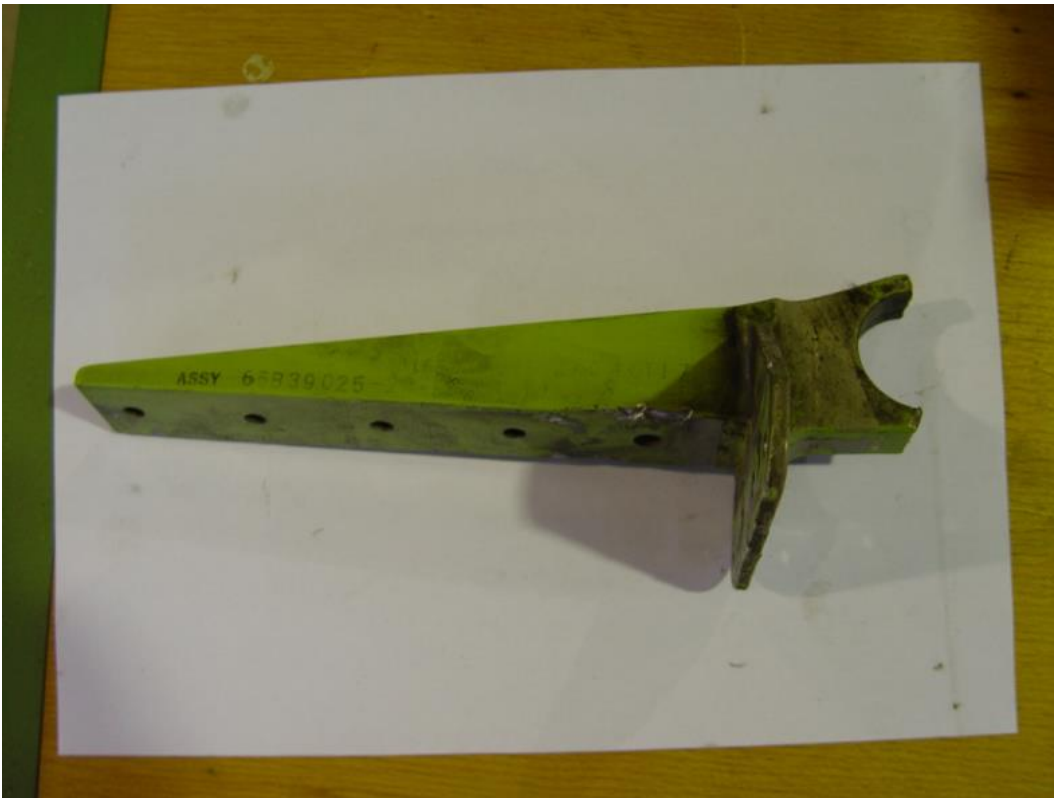

Image 9: Removed flap attach fitting

Source: BFU



Image 10: Part number of the fractured flap attach fitting

Source: BFU

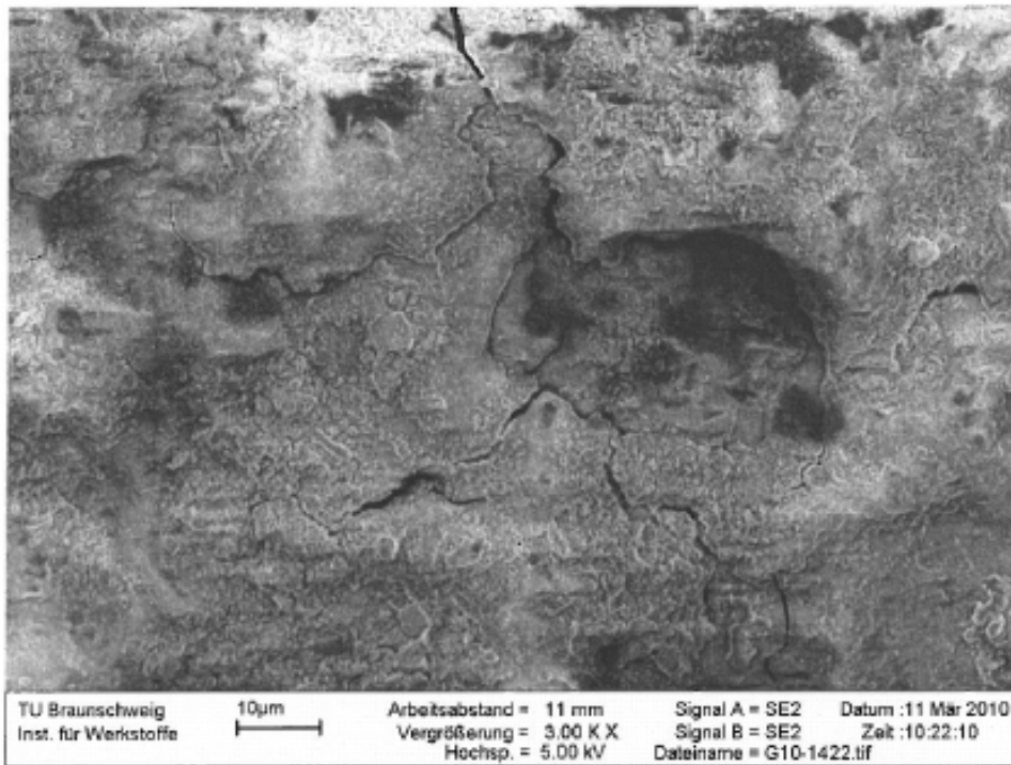

Image 11: Aluminium fretting oxidation plaques in the black starting area of the fatigue crack Source: ifw

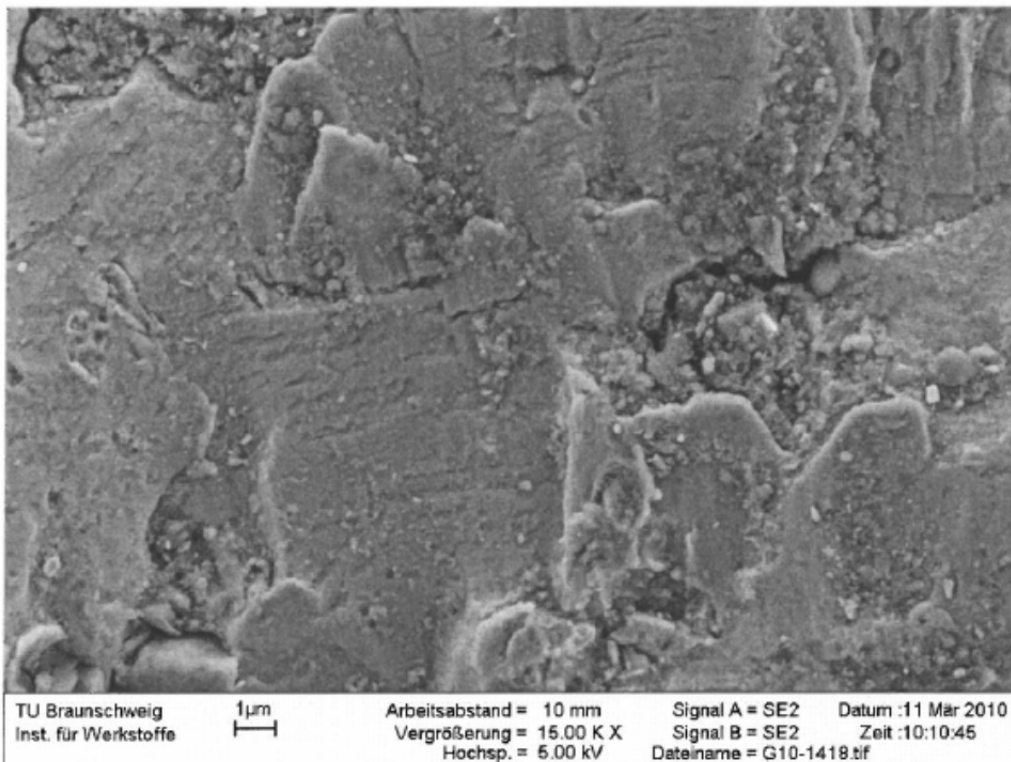

Image 12: Flattened striations in the metallic blank crack section

Source: ifw

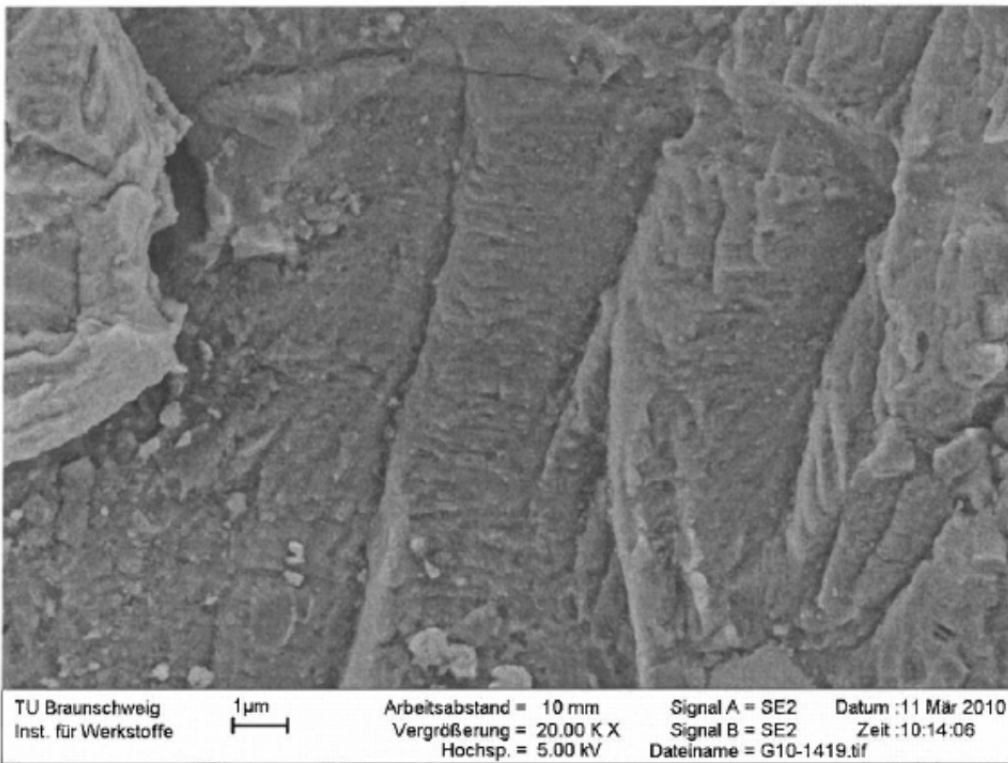

Image 13: Flattened striations in the metallic blank crack section

Source: ifw

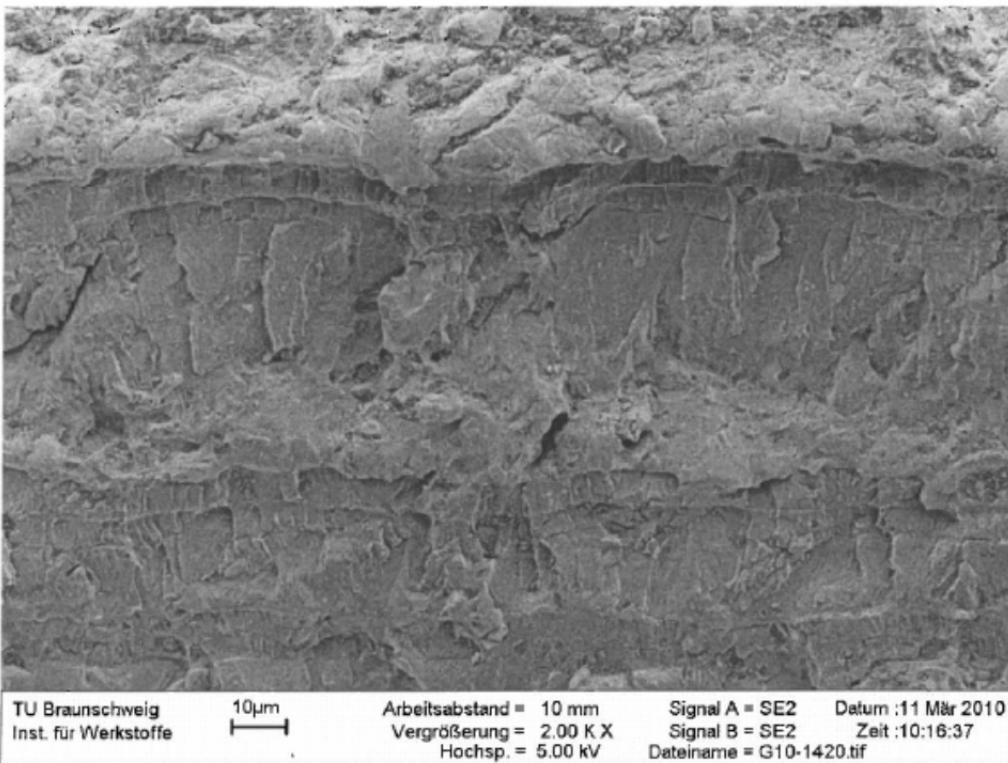

Image 14: Transition area between fatigue fracture and residual fracture

Source: ifw

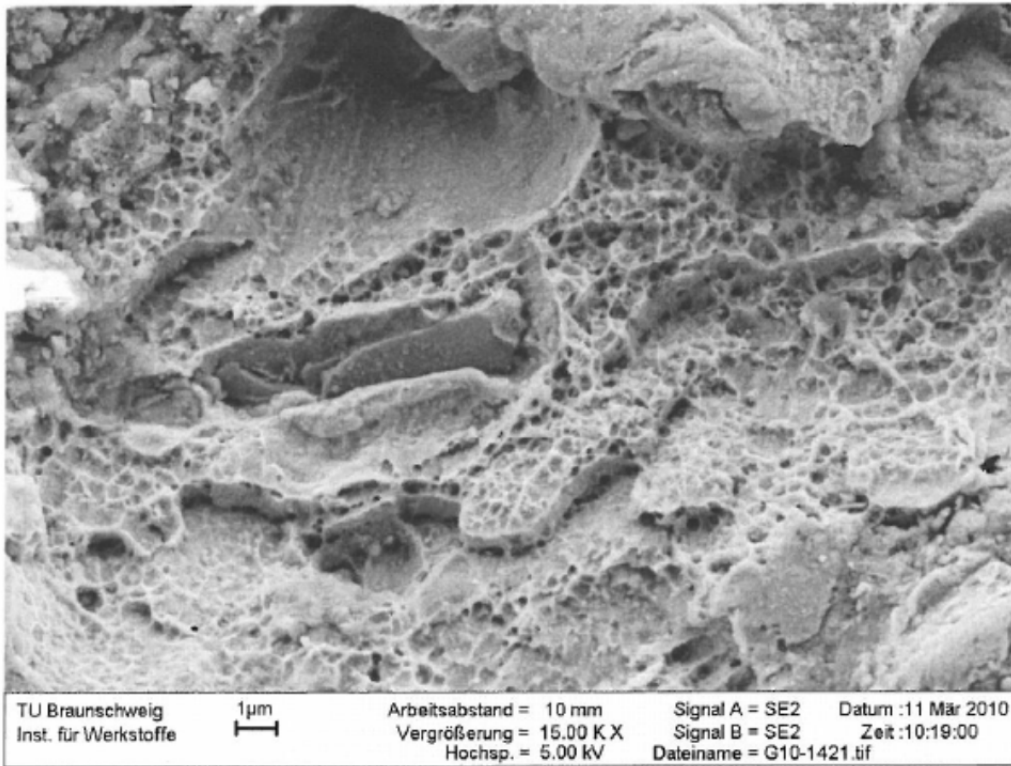

Image 15: Characteristic dimple structure in the area of the forced rupture

Source: ifw

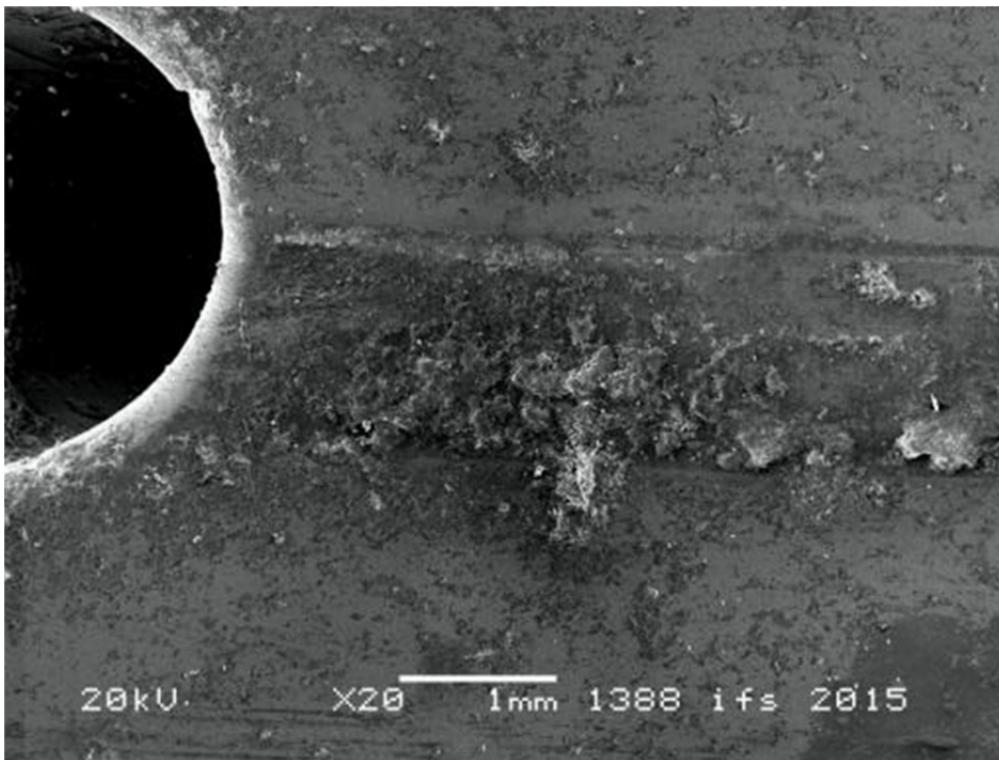

Image 16: Overview, left lubrication supply, middle hole corrosion, above "track area"

Source: ifs

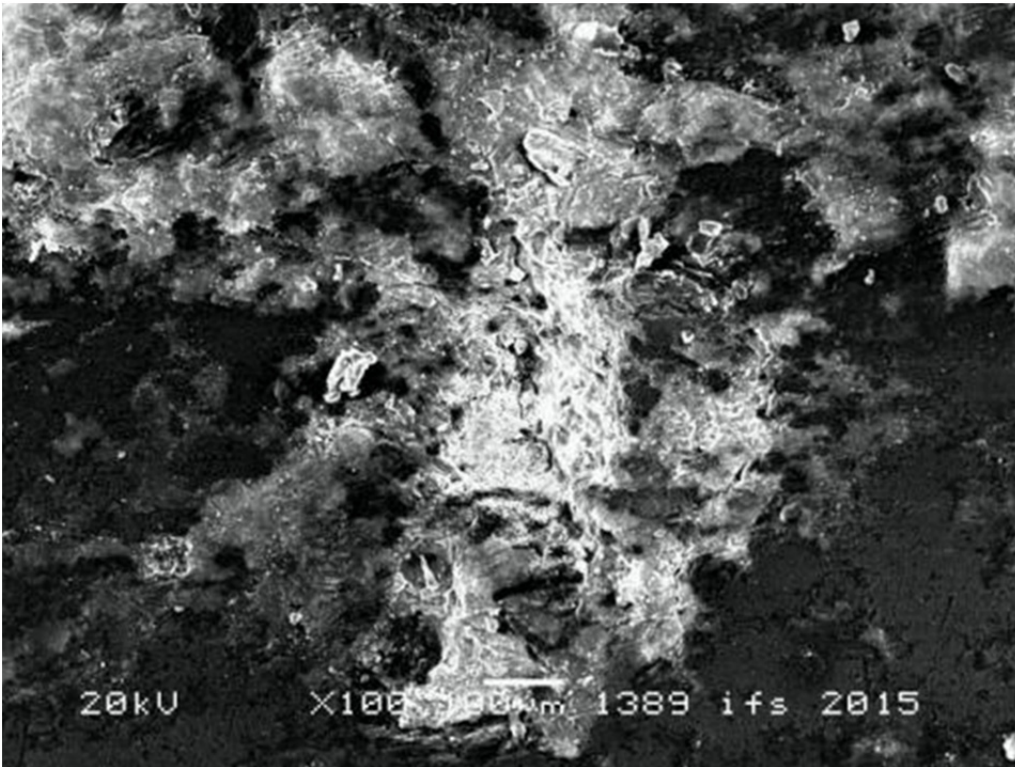

Image 17: Detail enlargement hole corrosion (hole filled with corrosion products)

Source: ifs

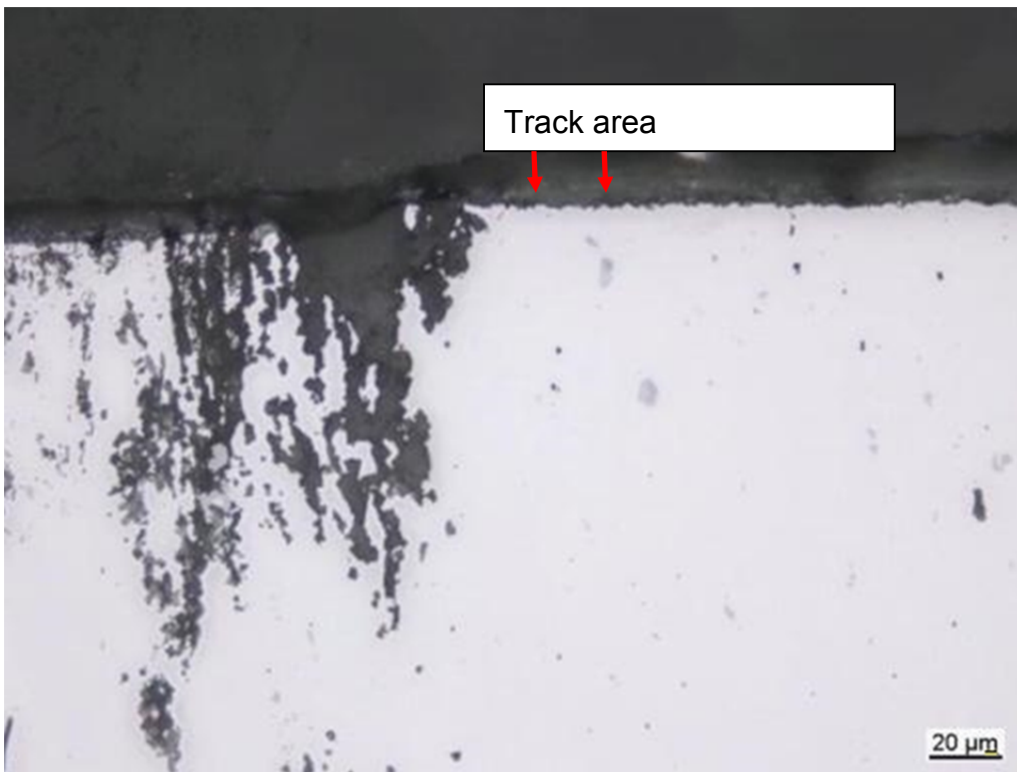

Image 18: Cross specimen with "track area" left to the strong corrosion

Source: ifs

JUN 25 1974

REVISION
TRANSMITTAL SHEET

Boeing Service Bulletin 747-57-2119

MF
747

This sheet transmits REVISION 2 dated June 20, 1975 to Service Bulletin 747-57-2119, "Inboard Trailing Edge Fore Flap Outboard Sequence Carriage Attach Fitting Replacement."

NOTE: This revision constitutes a complete reissue.

SUMMARY

Revision 1 of this bulletin requested a one-time inspection, with results reported to Boeing, and noted that repeat inspection requirements, if any, would be determined based on initial inspection results. Based on recent service experience and initial inspections, this revision is issued to specify a continuing inspection program on uncracked fittings until fittings are replaced with improved fittings. Please notify Boeing of planned action through the Boeing Customer Support Representative.

In addition, based on recent service experience, this revision emphasizes the benefit to be gained by early incorporation of this modification, as the new fittings provide considerably more strength to resist abnormal loading that can develop if the fore flap track rollers located in the mid flap are corroded or seized.

Also, during modification of an airplane at Boeing, it was found that the oversize bolts used to attach the fitting horizontal flange to the fore flap lower surface could not be installed in the nutplates because of interference with the bolt shank. Therefore, instructions are added in this revision to use nuts and washers rather than nutplates and new kits are defined. In addition, the Parts Accountability Table is revised to reflect the correct superseding part number, the effectivity is updated to reflect latest airplane ownership, and minor editorial changes are incorporated.

Airplanes modified per the previous releases of this bulletin may require additional rework if nutplates were installed on the fore flap for attachment of the fitting horizontal flange, and interference was encountered with the oversize fasteners. If this condition exists, the nutplates should be replaced with nuts and washers.

Summary and pages 1-8, 11-43 of this revision contain new or revised information.

REVISION HISTORY

Original Issue:	May 31, 1974
Revision 1:	September 24, 1974
Revision 2:	June 20, 1975

THE BOEING COMMERCIAL
AIRPLANE COMPANY
CUSTOMER SUPPORT



BOEING 747

BOEING COMMERCIAL AIRPLANE COMPANY

P.O. BOX 3707 SEATTLE, WASHINGTON 98124

SUBJECT:

 INBOARD TRAILING EDGE FORE FLAP
 OUTBOARD SEQUENCE CARRIAGE ATTACH
 FITTING REPLACEMENT

SERVICE BULLETIN SUMMARY

NO: 747-57-2119 DATE: May 31/74

REVISION 2: June 20, 19

=====	PLEASE NOTIFY BOEING	=====
=====	REPRESENTATIVE OF	=====
=====	PLANNED ACTION	=====

MATERIAL INFORMATION

<u>Kit</u>	<u>Price</u>
63B12156-10	\$984.00

BACKGROUND

A fatigue crack was found in the horizontal flange of the inboard fore flap outboard attach fitting on the fatigue test airplane after 12,000 simulated flights. Subsequently, three in-service cracks were reported at 2300 to 3500 flights. Undetected cracking could result in complete fracture of the fitting and loss of the fore flap in flight. Subsequent to Revision 1, three fore flap losses have been reported. The most recent loss, at 5508 flights, resulted in considerable damage to No. 4 door.

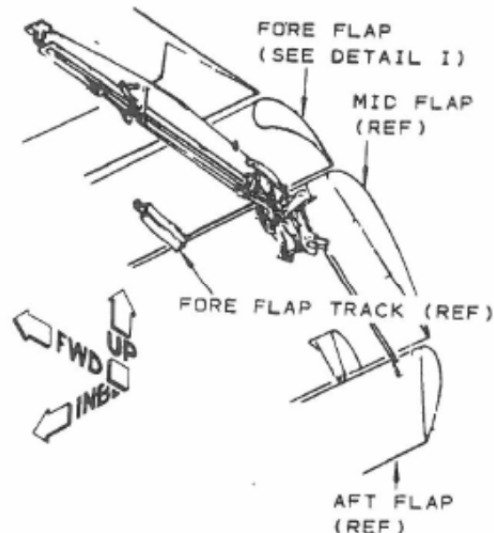

VIEW LOCKING UP AT INBOARD TRAILING EDGE FLAPS

ACTION (PRR 75602)

Inspect outboard sequence fitting for cracks on airplanes with over 2000 flights. Repeat inspection every 200-300 flights until the existing inboard fore flap outboard attach fitting is replaced with an improved fitting with thicker flanges.

EFFECTIVITY

Group I: Cum. Line - 001 thru 087

Group II: Cum. Line - 088 thru 151

Group III: Cum. Line - 152 thru 226

MANPOWER

Total Man-Hours - 50 (Mod.), 8 (Inspect)

Airplane Down-Time - 10.5 (Mod.), 2 (Inspect) Hours

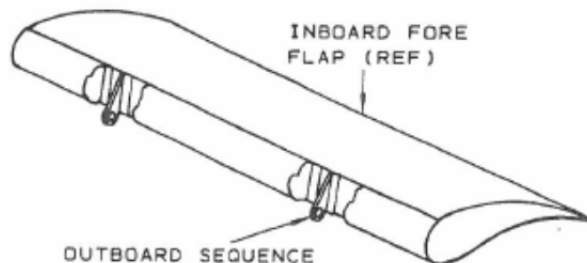

OUTBOARD SEQUENCE FITTING (REPLACE)

DETAIL I

Summary Page 1 of 1

BOEING

THE BOEING COMMERCIAL AIRPLANE COMPANY P.O. BOX 3707 SEATTLE, WASHINGTON 98124

SERVICE BULLETIN

 ATA
SYSTEM: 5750

NO: 747-57-2119

DATE: May 31, 1974

REVISION 2: June 20, 1975

SUBJECT: INBOARD TRAILING EDGE FORE FLAP OUTBOARD SEQUENCE
CARRIAGE ATTACH FITTING REPLACEMENT

I. Planning Information

A. Effectivity

1. Airplanes Affected

An equivalent change will be incorporated on applicable airplanes in production per PRR 75602. This service bulletin applies to 747 production cumulative line number 001 thru 226 in 3 groups as follows: Group I, cum. line 001 thru 087; Group II, cum. line 088 thru 151; Group III, cum. line 152 thru 226. Customer identification of applicable airplanes is listed below.

NOTE: Effectivity is divided into three groups to reflect differences in rework requirements.

CUSTOMER & CUSTOMER NO.	MODEL & SERIES	SEQ. SERIAL NO.	REGISTRY NO.
GROUP I			
AA (AMERICAN)	RA903-RA907	747-123 20102 THRU 20106	N9663 THRU N9667
	RA909	747-123 20109	N9669
AF (AIR FRANCE)	RA251-RA254	747-128 10740 THRU 10752	F-BDUE THRU F-BDUD
AR (ARGENTINAS)	22631	747-132 10006	*

* Registry number not available.

May 31/74
REV. 2: Jun 20/75

747-57-2119
Page 1 of 43

BOEING SERVICE BULLETIN NO. 747-57-2119

 B. Reason

This modification will reduce the possibility of fatigue cracking in the outboard attach (sequence) fitting for the inboard trailing edge fore flap.

The inboard trailing edge fore flaps are connected by two attach fittings to sequence carriages which move along each inboard flap track to establish the fore flap position. The fore flap is also supported by three tracks which extend into the mid flap on rollers.

A fatigue crack was found in the fillet radius between the lug and the horizontal flange of the fore flap outboard attach fitting on the fatigue test airplane after accumulation of 12,000 simulated flights. An undetected fatigue crack in a fore flap attach fitting could eventually result in complete fracture of the attach fitting. Complete fracture of the fore flap attach fitting would leave the outboard end of the fore flap unrestrained and partial or total loss of the fore flap could occur in flight, possibly causing damage to other airplane structure.

Subsequent to the original issue of this bulletin, three instances of cracking of the horizontal flange have been reported by two operators at 3482, 2900, and 2299 flights. All three cracks originated in a different location than the fatigue test crack. They were all found at the outboardmost fastener hole in the horizontal flange, and they propagated in an inboard-aft as well as outboard direction.

The cracks were caused by cyclic loading and are believed to be aggravated by a fit up problem which increased the stress level in the horizontal flange. Because of the direction of the operating side load, the highest stress level is expected to occur at the outboardmost fastener hole. The one-time inspection requested by Revision 1 of this bulletin resulted in 11 additional reports of cracks of this type.

BOEING SERVICE BULLETIN NO. 747-57-2119

Subsequent to Revision 1 of this bulletin, three instances of loss of the inboard fore flap have been reported by two operators. These losses have been attributed to cracking and subsequent breakage of the outboard attach fitting. In two of these instances, the failures were caused by higher than normal loads imposed on the fittings by corroded and seized fore flap track rollers, possibly aggravated by incorrect shimming of the fitting horizontal flanges. In the other instance, incorrect shimming of the horizontal flange of the fitting is believed to have been the major contributing factor in fitting failure.

The most recent instance of fore flap loss, which occurred at 5508 flights, resulted in damage to the body skin below passenger floor level and considerable damage to the No. 4 door due to impact by the departing fore flap.

C. Description

To reduce the possibility of fatigue cracks occurring in the inboard fore flap outboard attach fitting, the existing outboard fitting may be replaced with an improved fitting having increased fatigue life. The new fitting has a thicker flange where it is attached to the fore flap front spar vertical web. A doubler is required between the horizontal flange of the new fitting and the fore flap lower skin to provide proper fitting alignment in the vertical direction. The fitting also has a thicker horizontal flange.

The new outboard attach fitting will also provide additional strength to resist loads imposed on the fore flap if the rollers in the mid-flap become seized.

The effectivity has been divided into three groups to facilitate referencing to configurational differences. Group I airplanes were delivered with the "A" flap system and Group II and III airplanes were delivered with the "B" flap system. Conversion to the "B" flap system per Service Bulletin 27-2060, "Aft Trailing Edge Flap Track Fairing Actuator System Conversion" does not affect airplane rework.

NOTE: It is suggested that this service bulletin be accomplished concurrently with Service Bulletin 57-2088, "Wing Trailing Edge Inboard Foreflap Sequencing Fitting Replacement" on Group I and II airplanes to take advantage of common access requirements. Group III airplanes received the intent of Service Bulletin 57-2088 in production.

BOEING SERVICE BULLETIN NO. 747-57-2119

Based on recent service experience and results of previous inspections, it is recommended that the fitting horizontal flange at the fastener holes and in the fillet radius of the flange-to-bearing lug be penetrant or eddy current inspected for cracks on all affected airplanes with 2000 or more flights. Fastener removal is not required. Repeat inspections should be accomplished at regular maintenance intervals not to exceed 300 flights, until fitting replacement is accomplished. If cracked fittings were replaced with like fittings, rather than the new improved fittings, inspection of these fittings should commence after accumulation of 2000 flights.

Installation of the new fittings requires shim check and adjustment as required, and the new fittings provide considerably more strength to resist corroded or seized flap track rollers. Therefore, because of the potential for loss of inboard fore flaps, operators are encouraged to consider early incorporation of this modification.

Please notify Boeing of inspection plans and modification schedules through the Boeing Customer Support Representative.

NOTE: Reference to this bulletin is contained in Notice of Proposed Rule Making Docket No. 75-NW-16-AD dated June 2, 1975.

D. Approval

The replacement described herein has been approved by the FAA Designated Engineering Representative at the Boeing Commercial Airplane Company and coordinated with FAA Northwest Region.

This investigation was conducted in accordance with the regulation (EU) No. 996/2010 of the European Parliament and of the Council of 20 October 2010 on the investigation and prevention of accidents and incidents in civil aviation and the Federal German Law relating to the investigation of accidents and incidents associated with the operation of civil aircraft (*Flugunfall-Untersuchungs-Gesetz - FIUUG*) of 26 August 1998.

The sole objective of the investigation is to prevent future accidents and incidents. The investigation does not seek to ascertain blame or apportion legal liability for any claims that may arise.

This document is a translation of the German Investigation Report. Although every effort was made for the translation to be accurate, in the event of any discrepancies the original German document is the authentic version.

Published by:

Bundesstelle für
Flugunfalluntersuchung
Hermann-Blenk-Str. 16
38108 Braunschweig

Phone +49 531 35 48 - 0
Fax +49 531 35 48 - 246

Mail box@bfu-web.de
Internet www.bfu-web.de