

Investigation Report

Identification

Type of Occurrence:	Serious incident
Date:	19 December 2010
Location:	Köln/Bonn
Aircraft:	Airplane
Manufacturer / Model:	Airbus / A319-132
Injuries to Persons:	Two persons with minor injuries
Damage:	None
Other Damage:	None
Information Source:	Investigation by BFU
State File Number:	BFU 5X018-10

This investigation was conducted in accordance with the regulation (EU) No. 996/2010 of the European Parliament and of the Council of 20 October 2010 on the investigation and prevention of accidents and incidents in civil aviation and the Federal German Law relating to the investigation of accidents and incidents associated with the operation of civil aircraft (*Flugunfall-Untersuchungs-Gesetz - FIUUG*) of 26 August 1998.

The sole objective of the investigation is to prevent future accidents and incidents. The investigation does not seek to ascertain blame or apportion legal liability for any claims that may arise.

This document is a translation of the German Investigation Report. Although every effort was made for the translation to be accurate, in the event of any discrepancies the original German document is the authentic version.

Published by:

Bundesstelle für
Flugunfalluntersuchung

Hermann-Blenk-Str. 16
38108 Braunschweig

Phone +49 531 35 48 - 0
Fax +49 531 35 48 – 246

Email: box@bfu-web.de
Internet: www.bfu-web.de

Content	Page
Identification	1
Abbreviations	6
Synopsis	8
1. Factual Information	9
1.1 History of the Flight.....	9
1.1.1 General Description of the Situation	17
1.2 Injuries to Persons	18
1.3 Damage to Aircraft.....	19
1.4 Other damage.....	19
1.5 Personnel Information.....	19
1.5.1 Pilot in Command (PIC).....	19
1.5.2 Co-pilot	19
1.5.3 Purser	20
1.6 Aircraft Information	20
1.6.1 Air-Conditioning of the Aircraft Interior.....	20
1.6.2 Rain Repellent System	23
1.6.3 Aircraft Maintenance.....	25
1.7 Meteorological Information	25
1.8 Aids to Navigation.....	26
1.9 Radio Communications.....	27
1.10 Aerodrome Information	27
1.11 Flight Recorders	27
1.12 Wreckage and Impact Information	27
1.12.1 Determinations on the Aircraft	27
1.12.2 Airborne Particles in the Atmosphere	28
1.13 Medical and Pathological Information	29
1.13.1 History	29
1.13.2 Statement of the Medical Expert.....	30
1.14 Fire	33
1.15 Survival Aspects	33
1.16 Tests and Research.....	33
1.17 Organisational and Management Information	34

1.71.1	Procedures for Smell and/or Smoke Events	34
1.17.2	Use of the Oxygen Masks	36
1.18	Additional Information	37
1.18.1	Reporting Procedure	37
1.18.2	Physiological and Psychological Effects of Smell.....	40
1.18.3	Aircraft History.....	41
1.19	Useful or Effective Investigation Techniques	42
1.19.1	Determination of Flight Parameters from QAR Data	42
2.	Analysis	43
2.1	General	43
2.2	Analysis of the Flight from the Operational Viewpoint	44
2.3	Specific Conditions.....	47
2.3.1	Crew.....	47
2.3.2	Weather	47
2.3.3	Aircraft De-Icing	48
2.4	Human Performance	48
2.4.1	General Co-Operation and Working Atmosphere.....	48
2.4.2	Odour Development in the Cockpit and the Handling of the Situation.....	49
2.4.3	Making Use of Available Resources.....	50
2.5	Technical Aspects	52
2.5.1	Aircraft Climatic System	52
2.5.2	Determinations on the Airplane and Maintenance.....	54
2.6	Assessment of Possible Influencing Factors	54
2.6.1	Aerotoxic Syndrome.....	54
2.6.2	Differential Diagnosis	55
2.6.3	Assessment of Additional Influencing Factors.....	58
2.6.4	Physiological and Psychological Effects of Smell.....	61
2.7	Defences	62
2.7.1	Oxygen Masks	62
2.7.2	Checklists and Training.....	63
2.7.3	Safety Gate (1,000 ft).....	63
2.8	Organisational Aspects	64
2.8.1	Reporting Process.....	64
2.8.2	Flow of Confidential Information.....	65

3.	Conclusions	66
3.1	Findings	66
3.2	Causes	68
4.	Safety Recommendation	68
5.	Appendices	69

Abbreviations

AAIU	Air Accident Investigation Unit
ACM	Air Cycle Machine
AGL	Above Ground Level
AOC	Air Operator Certificate
AMSL	Above Mean Sea Level
APU	Auxiliary Power Unit
ATA	Air Transport Association
ATPL (A)	Airline Transport Pilot License (Aeroplane)
BFU	Federal Bureau of Aircraft Accident Investigation
CISM	Critical Incident Stress Management
CM1	Crew member 1
CM2	Crew member 2
CRM	Crew Resource Management
CVR	Cockpit Voice Recorder
DWD	German Meteorological Service
EASA	European Aviation Safety Agency
ECS	Environmental Control System
EU-OPS	European Regulation
FDR	Flight Data Recorder
FIUUG	Law Relating to the Investigation into Accidents and Incidents Associated with the Operation of Civil Aircraft
FL	Flight Level
FODA	Flight Operations Data Analysis
ILS CAT-II/III	Instrument Landing System Category II/III

LOC / GS	Localizer / Glideslope
METAR	Aviation Routine Weather Report
NM	Nautical Mile
OM-A	Operations Manual Part A
OM-B	Operations Manual Part B
QAR	Quick Access Recorder
QRH	Quick Reference Handbook (QRH)
PF	Pilot Flying
PNF	Pilot non Flying
RWY	Runway

Synopsis

On 19 December 2010 the Airbus A319 coming from Vienna, Austria, was on approach to Köln/Bonn Airport, Germany. Turning on to the base leg the two pilots noticed an abnormal smell. A short time later during intercept of the extended centre line, both pilots noticed an adverse effect on their physical and cognitive performance. They donned their oxygen masks and declared emergency. The Pilot in Command (PIC) remained able to steer the airplane. The co-pilot felt he could no longer perform his tasks in the cockpit without restrictions. After the landing and having reached the parking position, both pilots sought medical treatment. Whereas the PIC could resume his duties after four days, the co-pilot remained unfit to fly until 10 July 2011. The technical inspection of the aircraft did not reveal any indication of a technical malfunction.

Cause:

The health impairments of both pilots combined with a significant limitation of the capability to perform which had occurred during the approach were very likely caused by:

- Massive development of smell in the cockpit area whose origin and spread could not be determined.

Contributing factors could have been:

- Physiological and psychological effects of the smell on both crew members

1. Factual Information

1.1 History of the Flight¹

According to the statements of the cockpit crew, at 1325 hrs² the rested crew reported for duty at Köln/Bonn Airport.

The first flight leg would take them to Vienna. They were further scheduled to return to Köln/Bonn and then fly to Milan, Italy, and back.

The weather report for that day predicted heavy snowfall in Köln/Bonn. Both pilots knew each other from a flight rotation two days previously which was also characterised by challenging winter flight operations. During the outside check in Köln/Bonn it began to snow. The airplane was de-iced at the parking position. Both pilots stated the take-off and flight to Vienna occurred without any incidents.

While the airplane was ready to depart Vienna the ever increasing snowfall made the weather conditions in Köln/Bonn worse. The crew had decided to board the passengers later since they expected a delay. When Köln/Bonn Airport was closed due to continuous heavy snowfall the crew realised they might not be able to conduct the scheduled flights according to plan.

After about three hours the snowfall in Köln/Bonn began to decrease and once the airplane became a slot for about 50 minutes later the crew started the boarding process. Due to a speedy de-icing process - with engines running - at the stop area designated for the process and a short way to taxi the airplane left the airport at 2012 hrs in the last minute of the allotted slot. During taxiing and take-off the air condition (packs) was off so that no de-icing fluid would penetrate the aircraft ventilation circuit, among other things.

The QAR data showed that after take-off in Vienna the aircraft turned left toward the north-west and climbed to a cruising altitude in Flight Level (FL) 360 which was reached at 2031 hrs.

The crew stated cruise flight to Köln/Bonn occurred without incident. The PIC (CM1) was the Pilot Flying (PF) during this leg. Both pilots were aware that because of the delay of now four hours they would no longer be flying to Milan.

¹ The factual information is solely based on the statements of both pilots and the evaluation of the data of the Quick Access Recorder (QAR).

² All times local, unless otherwise stated.

After 20 minutes in FL 360 descent to FL 300 was initiated. At 2057 hrs the aircraft levelled off at this flight level. Four and a half minutes later the descent was continued until 2120 hrs at which point FL 70 was reached.

The crew stated, the approach to the destination airport was almost completely a continuous descent and both pilots described the working atmosphere as professional. The radar controller issued headings guiding them to the Instrument Landing System (ILS) of runway 14L.

According to the QAR data, at 2124 hrs the airplane left FL 70 and within about three minutes descended down to 4,000 ft AMSL, QNH 987 hPa. Heading was 280° at the time. Once the airplane reached 4,000 ft AMSL the Airbus A319 was about 20 km north of the arrival aerodrome Köln/Bonn. Two and a half minutes later the airplane began the descent to 3,000 ft and turned left toward the final approach of runway 14L.

At an altitude of 4,000 ft and during the turn into the left base leg (Appendix 1: Instrument Chart Köln/Bonn, runway 14L, ILS) both pilots noticed a strange, strong and unpleasant smell for the first time - a mixture of burnt and electrical smell. The co-pilot had noticed the intensive smell as "elektrisch-süß" (electrically sweet) which felt "dicht" (dense) on breathing in. On enquiry, the purser reported there was no unusual smell in the entire cabin. After a short time, for the two pilots it seemed the smell had begun to subside.

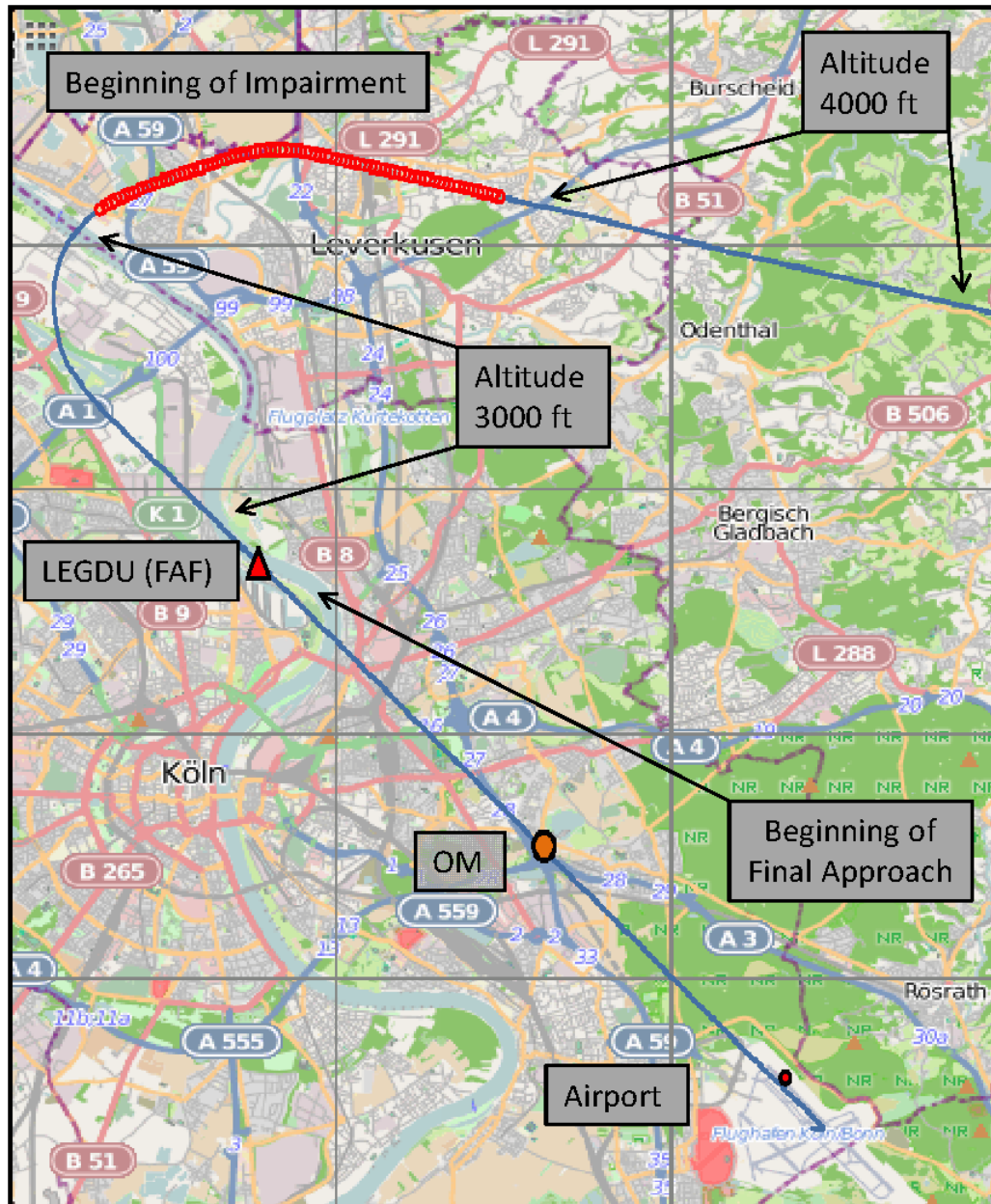

Image 1: Flight path

Source: FODA/BFU

During the subsequent intercept of the localizer the co-pilot (CM2) said he felt seriously sick and intended to don his oxygen mask. He stated that the nausea had hit him like a punch to his stomach. Once his arms and legs began to feel numb and he noticed he could no longer think clearly, he grabbed his oxygen mask and at the second attempt he successfully donned it.

According to his statement, alarmed by this and watching his own body the PIC also suddenly felt an intense prickling in his hands and feet. At the same time he became aware "im wahrsten Sinne des Wortes die Sinne schwanden" (how his senses were literally failing him). His field of vision became suddenly restricted (tunnel vision) and he felt severe dizziness. In this situation he grabbed his oxygen mask.

After the PIC and the co-pilot had donned their oxygen masks they quickly established communications via their masks. The pilots stated that afterwards the PIC felt slightly better whereas the co-pilot continued to feel sick. His condition became rather worse.

According to the pilots' recollection by then the airplane had already been aligned with the ILS localizer. A speed of 220 kt was pre-selected on the autopilot for the final approach.

The recorded QAR data showed the airplane had been aligned with the extended centre line about 11 NM prior to touch-down. The ground speed was approximately 240 kt.

About 9 NM prior to touch-down, as the ILS glideslope was reached, the airplane began to descend. The aircraft was flying slightly above the glideslope; at a distance of about 8 to 7 NM prior to the runway threshold the deviation was about 150 ft above the glideslope. At the beginning of the descent the ground speed was about 240 kt and decreased to 170 kt as the outer marker (3.9 NM prior to touch-down) was reached.

According to the description of the crew, after the glideslope indication had come on the PIC instructed the Pilot None Flying (PNF) to inform the approach controller that they wanted to change to the tower frequency. Once he talked to the tower controller he should then declare mayday which the co-pilot did. In the meantime, the PF had moved the flaps into the first position and once the glideslope began to move towards the middle of the indication he had disengaged the autopilot. Thus the PIC flew the airplane manually. According to the PIC's statement, the airplane did not decelerate fast enough and the PF therefore asked the PNF to extend the landing gear and then move the flaps into position 2. The PF had already extended the speed brakes.

The PIC did not feel he was physically or psychologically in a position to fly a missed approach procedure and told the co-pilot that he would suspend the 1,000 ft safety gate (all parameters for the landing have to be reached to continue the approach). For him an immediate landing was the only thing worth considering.

The recorded QAR data showed that shortly before reaching the outer marker the airplane was briefly once again about 100 ft above the glideslope. While the outer marker was overflown the airplane descended about 50 ft below the glideslope (deviation lasted for about 30 seconds total). The outer marker was passed with about 170 kt ground speed. During the remainder of the approach until the touch-down the airplane was on the glideslope.

After the pilots had configured the airplane for landing the speed which was still too high had to be reduced further before touch-down.

About 25 seconds after the outer marker had been passed the aircraft flying with about 135 kt ground speed was in about 1,000 ft above the runway threshold. Within the subsequent 50 seconds the ground speed decreased to about 125 kt and the altitude to about 600 ft above the threshold. In the subsequent 20 seconds speed increased. The airplane overflew the threshold in about 60 ft and with a ground speed of 135 kt.

The airplane touched down at 2134 hrs with a ground speed of 135 kt, about 365 m (1,200 ft) behind the threshold and used autobrake. According to the PIC at a speed of about 40 kt he began to brake manually. Forty seconds after touch-down, after about 1,300 m, the aircraft left runway 14L with a ground speed of about 10 kt and entered taxiway A3.



Image 2: Touch-down and turn-off point of the airplane based on the QAR data

Source: Google/BFU

During taxiing on taxiway A the PIC handed the airplane over to the co-pilot (now PF) so that he could communicate via radio with the fire brigade who accompanied the airplane. He also contacted the purser again to let him know he would make an announcement over the intercom to the passengers once they had reached the parking position, opened the windows and removed the oxygen mask. The co-pilot stated he concentrated so hard on steering the airplane that he did not follow the conversation between PIC and fire brigade. After the PIC had finished his conversation he once more took over as PF. After they had entered taxiway B the co-pilot called their attention to the settings they had to select and the retraction of the flaps (after landing items) they had yet to do. While they were following the follow-me vehicle to the parking position they completed these items.

After the parking brake had been set both noticed that the Auxiliary Power Unit (APU) had not yet been started and did so. The co-pilot stated he needed three attempts to open the window. Once he had opened the window he removed his oxygen mask and since he again noticed the burning smell he promptly donned his mask again.

Because flashing blue lights were visible next to the airplane the PIC did not want to wait any longer with addressing the passengers with an explanatory announcement. With the window open and still running engines he explained the presence of the fire brigade. According to the purser the passengers accepted the announcement well. Then the two pilots completed the parking checklist.

In the passenger cabin no one noticed any of the events in the cockpit. Not until the purser entered the cockpit, after they had reached the parking position, did he notice the unusual smell.

Before the passengers disembarked the officer-in-charge of the fire brigade entered the cockpit. Paramedics supported the co-pilot to the waiting ambulance. The PIC remained in the cockpit to make arrangements with the officer-in-charge of the fire brigade for the further course of action and to make another announcement to the passengers. He stood in the door to the cockpit while the passengers disembarked. His impression was that the passengers disembarked in a quiet and friendly mood.

Within a short time period after the last passenger had left the airplane, several people approached the PIC wanting his attention. But he met with the cabin crew first for a short meeting to give them a description of what had occurred. He advised them of the option to get support from the CISM team and then let them disembark. Then he talked with the technicians and made entries in the tech log. At this point he heard for the first time that de-icing fluid might possibly be responsible for the smell.

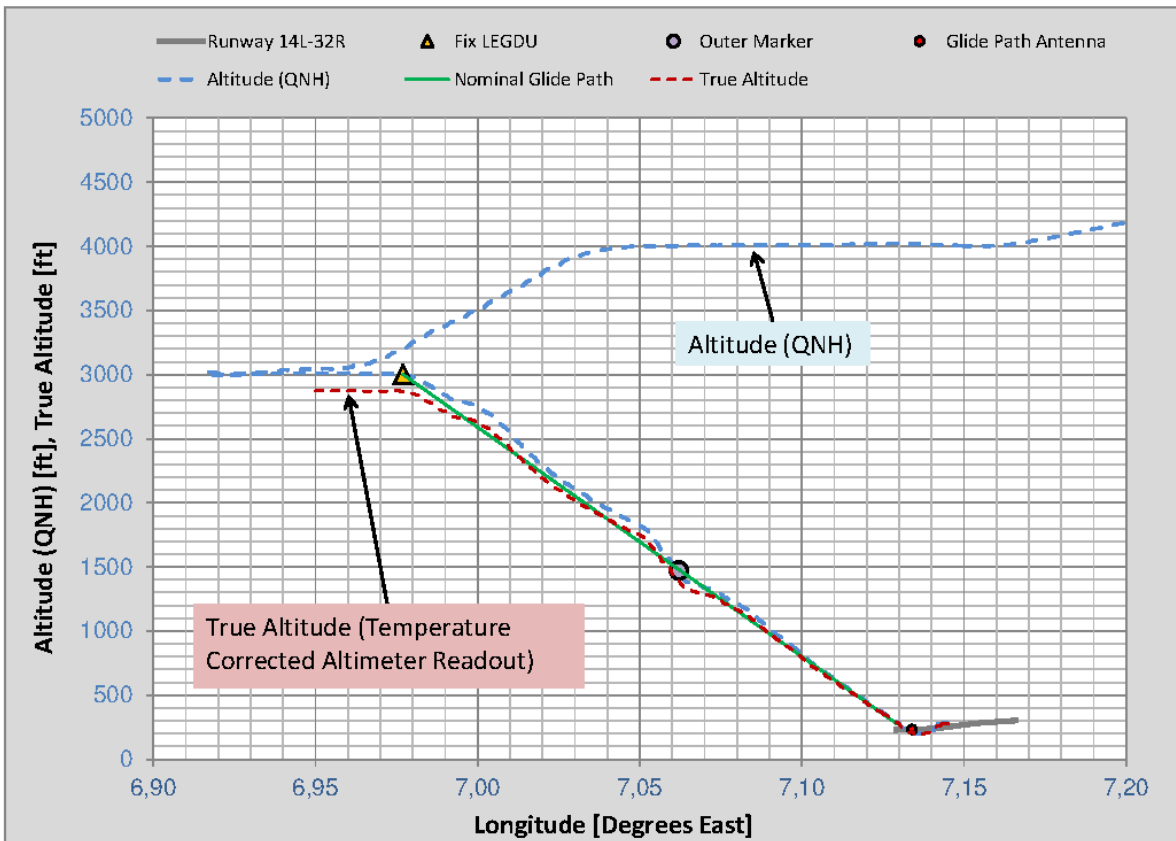
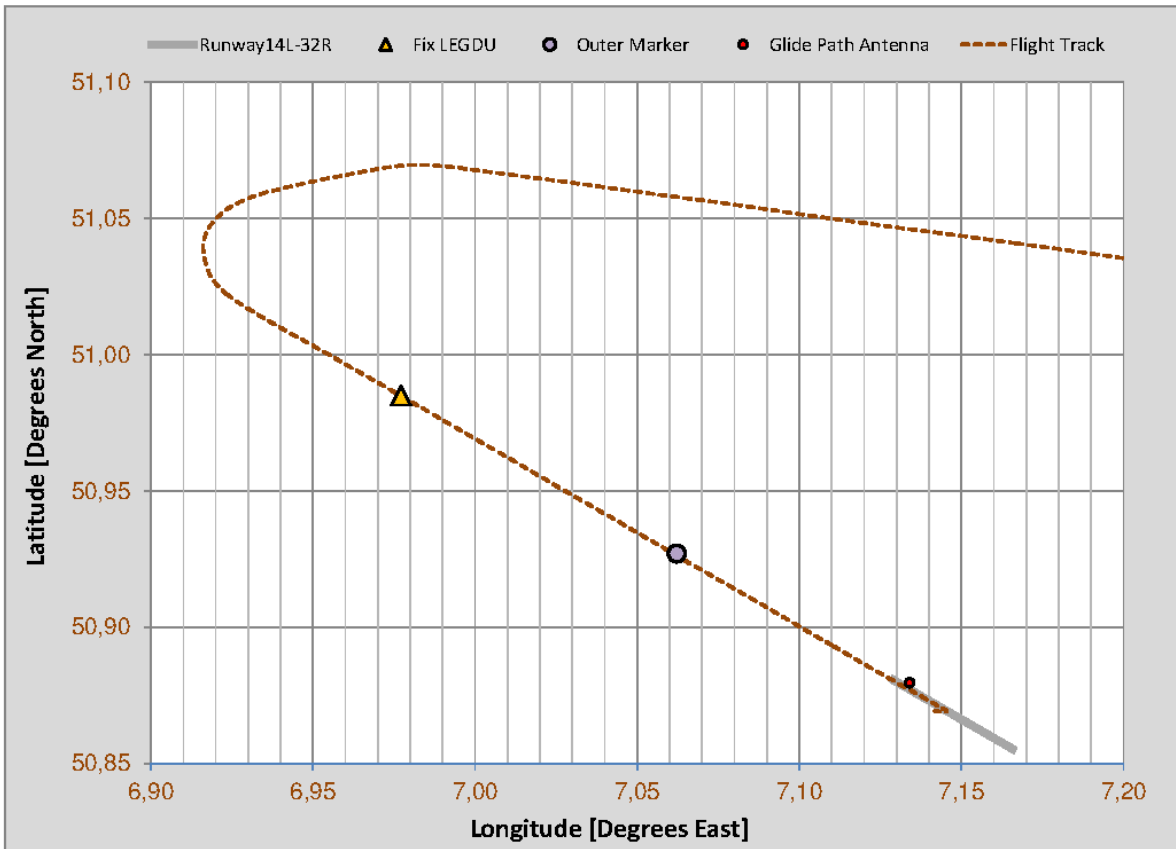

Image 3: Reconstructed flight path

Source: FODA/BFU

1.1.1 General Description of the Situation

The BFU interviewed the two pilots twice individually. The following description of the situation was the result:

The co-pilot had difficulties to comprehend the course of events in its entirety. He could narrowly concentrate on individual aspects of the events and realised he could no longer process the incoming information.

The PIC stated he had reached the limit of his capability to perform. Among other things, he felt distracted by the sound of his own breathing audible inside the oxygen mask and perceived it as disturbing the communication with the co-pilot. During the entire approach he felt physically ill. He was at the upper limit of what he thought he could do while manually flying the airplane with the assistance of the flight director.

The fact that his capability to perform was so limited scared him. He briefly thought about performing an autoland landing but dismissed this thought right away because he could not focus clearly and too many things have to be considered for an autoland landing. The only thing which still worked "vollautomatisch" (fully automated) due to his long flying experience was the manual steering of the airplane.

To the co-pilot the last two minutes between 1,800 ft and the touch-down felt like an eternity. He did not feel capable to actively influence the course of events and just hoped it would be a successful landing. He noticed, however, that the approach speed was now correct, but the checklist had not been completed and he then partially completed it. He realised how exhausting these activities were and how difficult it was to think and concentrate.

Both pilots described their condition shortly before touch-down as surreal and like a dream.

1.2 Injuries to Persons

Injuries	Crew	Passengers	Third Party
Fatal			
Serious			
Minor	2		
None	3	142	

The BFU asked both pilots how they would assess their physiological and psychological limitations during the final approach to Köln/Bonn Airport. As description and decision-making aid the crew members received the classification of crew incapacitation³ the Safety Regulation Group of the British Civil Aviation Authority (CAA) developed.

This classification divides crew incapacitation into the following subdivisions and severities, respectively:

Incapacitation - Unable to perform any duties.

Partial Incapacitation – Able to perform duties but with great difficulty.

Impairment – Able to perform duties with some difficulty and/or minor mistakes made.

Slight Impairment – Able to perform duties with little difficulty but with reduced efficiency.

Feeling unwell but no impairment (e.g. headaches, nausea).

Irritation but not impairment (e.g. of eyes, nose, throat).

The PIC rated the limitation of his capabilities as "Impairment" or "Partial Incapacitation". He rated his condition after he disembarked as "Slight Impairment".

The co-pilot rated the limitation of his capabilities as "Partial Incapacitation".

³ BRE/RAeS CAQ Conference, 16/17 October 2003, Safety Regulation Group, Civil Aviation Authority (UK)

The cabin crew did not feel impaired at all.

The BFU did not explicitly interview the passengers. The passengers gave no evidence that they had been affected.

1.3 Damage to Aircraft

There was no damage to the aircraft.

1.4 Other damage

There was no other damage to persons or property.

1.5 Personnel Information

1.5.1 Pilot in Command (PIC)

The 35-year-old pilot in command held an Airline Transport Pilot's License (ATPL (A)) issued according to JAR-FCL, German. He had a type rating as PIC for Airbus A318/319/320/321. He was licensed for flights according to Instrument Flight Rules (IFR) and CAT III landings. His total flying experience was 8,535 hours; 7,864 hours of which on airplanes with more than 20 t and 3,107 hours on the type. He held a class 1 medical certificate issued in accordance with ICAO and JAR-FCL 3 which was valid until 30 March 2011 without restrictions.

On the day of the occurrence, he had been on duty for nine hours, and had previously been off duty for more than 14 hours.

1.5.2 Co-pilot

The 26-year-old co-pilot held a Commercial Pilot's License (CPL(A)) with ATPL credit and MCC entry, issued in accordance with JAR-FCL, German. He had a type rating as co-pilot for Airbus A318/319/320/321. His total flying experience was 720 hours, of which 472 hours were on the aircraft type in question. He held a class 1 medical certificate issued in accordance with ICAO and JAR-FCL 3 which was valid until 13 August 2011 without restrictions.

On the day of the occurrence, he had been on duty for nine hours, and had previously been off duty for more than 14 hours.

1.5.3 Purser

The 41-year-old purser had been employed as flight attendant by the company in 2002. Prior to this employment he had been employed as flight attendant by a different operator.

On the day of the occurrence, he had been on duty for nine hours, and had previously been off duty for more than 13 hours.

1.6 Aircraft Information

The Airbus A319 is a shortened version of the A320 family to which also the A318 with an even shorter fuselage and the elongated version A321 belong.

The airplane involved is an Airbus A319-132; year of manufacture is 2008. In this version the airplane is 33.84 m long and has a wing span of 34.09 m. According to the aircraft register the aircraft had a maximum take-off mass of 75,500 kg and the operator had fitted it with 150 seats.

The airplane is equipped with two IAE V2524-A5 engines. Until the occurrence, aircraft and engines had completed 8,741 flight hours and 6,264 cycles.

On the day prior to the occurrence the airplane flew four legs. On the day of the occurrence it had flown from Köln to Munich and back prior to the occurrence leg. These two flights were uneventful.

In the week prior to the occurrence the airplane had been de-iced a total of 11 times because of the prevailing weather.

1.6.1 Air-Conditioning of the Aircraft Interior

The air exchange and pressure and temperature in transport aircraft are controlled by climate control systems. In aircraft of the Airbus family this system is called Environmental Control System (ECS).

The ECS is described in the Aircraft Manual (AMM) as follows:

The air conditioning system gives satisfactory values of pressure, temperature and freshness of the air in the pressurized fuselage.

Sub-systems

The air conditioning system consists of the following sub-systems:

- Distribution
- Pressurization control
- Air cooling
- Temperature control

Distribution

The distribution system delivers conditioned air to the pressurized fuselage.

Pressurization control

The pressurization control system controls the pressure in the fuselage. It operates fully automatically and has a manual backup. The pressure change rate is controlled to give satisfactory pressure values of safety and comfort for the passengers and crew.

Air Cooling System

The air cooling system decreases the temperature of the hot bleed air from the pneumatic system. It also reduces the quantity of water in the hot bleed air. Emergency ram air is supplied if there is a failure in the two air conditioning packs.

Temperature Control System

The temperature control system controls the temperature of the air supplied to the cockpit and cabin. You can adjust the temperature in the cockpit and the cabin independently.

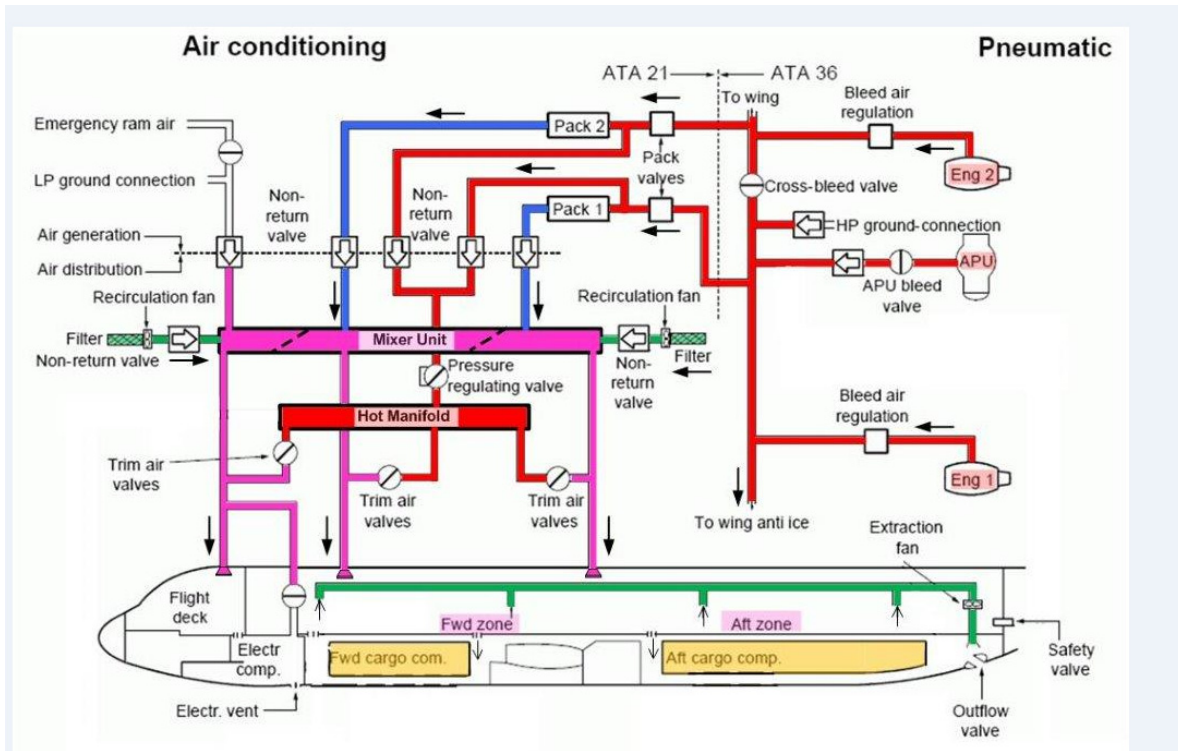

Image 4: Simplified diagram of the ECS

Source: Airbus, adapted by BFU

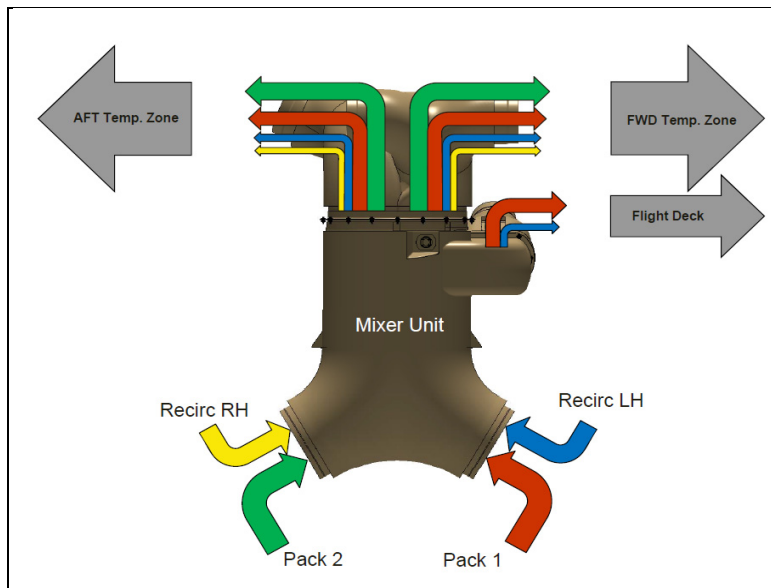

Image 5: Simplified diagram of the mixer unit

Source: Airbus

The ECS is supplied with air from the pneumatic system (ATA 36). Bleed air from the engine compressors or the compressed air from the APU is fed into it. Then two Air Cycle Machines (ACM), so-called packs, cool down a large part of the air. The mixer unit mixes this cooled air with air from the cabin (recirculating air).

The aircraft manufacturer provided information which contained the distribution of the air flow within the mixer unit. In normal operation both, the front and aft part of the cabin, are supplied with air from both packs (red and green arrow) and from both recirculating fans (blue and yellow arrow). The cockpit receives air from the left pack and the left recirculating fan only.

At the outlet of the mixer unit the amount of air from pack 1 which is fed into the cockpit is approximately 2.3 times higher than the air fed to the front part of the cabin. Prior to feeding the air to the respective zone, trim air from the hot manifold is added depending on the selected temperature. All zones receive the same trim air which originates either from engine 1 or engine 2 depending on the pressure ratio. During regular operating conditions the cabin zones require less trim air than the cockpit due to the higher temperatures in the cabin. The percentage of trim air for the cockpit is less than 10% of the total air flow.

The airflow in the fuselage is the reason for a very frequent exchange of air in the cabin. In FL 390, at 24°C cabin temperature and both packs engaged, Airbus states a transfer rate of about 70 times per hour in the cockpit (including recirculating air). The exchange of fresh air occurs about 47 times per hour. In the cabin the rate is about 36 times per hour for the entire air and about 24 times per hour for the fresh air. Under these conditions the amount of recirculating air is about 33%.

In the area of the mixer unit air is taken for the pressurisation of the hydraulic system, the water reservoir and the rain repellent system.

The cargo compartments of the airplane were not equipped with a ventilation system.

1.6.2 Rain Repellent System

The airplane is equipped not only with wind shield wipers but also with a liquid system which is supposed to improve visibility of the wet front panel.

An exchangeable cartridge contains up to 475 cm³ of the rain repellent liquid. This cartridge is installed behind the PICs seat. The BFU has no knowledge of the amount of fluid remaining in the cartridge at the time of the occurrence.

When the system is activated Nitrogen is used to spray the liquid through the spray nozzles on to the wind shield. When no fluid is sprayed, engine bleed air is used to keep the spray nozzles open. Check valves prevent rain repellent fluid to enter the ECS.

The aircraft manufacturer stated that the rain repellent contains aromatic substances (pine tree, spruce needle) which allow the crews to recognise leakages.



Image 6: Rain repellent cartridge Source: BFU

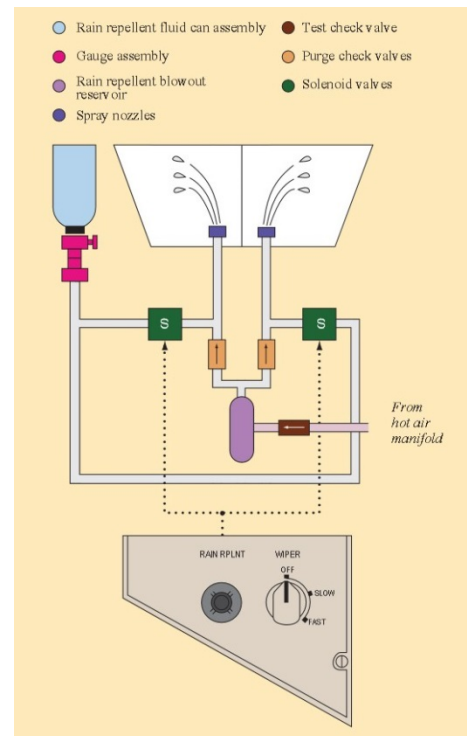

Image 7: Rain Repellent System (Airbus)

1.6.3 Aircraft Maintenance

The BFU received the maintenance documentation of the aircraft in question from the operator.

The aircraft was operated by a German operator. Thus Commission Regulation (EC) No 2042/2003 Appendix 1 (Part M) had to be applied.

The operator stated that in the four days prior to the occurrence five work orders were processed. These were four ordinary daily checks and the replacement of a light bulb. According to the documentation provided to the BFU there were no findings which could be connected with the occurrence. During this time period 16 flights with a total of 22 hours of flight time were conducted with the aircraft.

After the occurrence the avionic equipment ventilation system was inspected and the filter elements were replaced; the engine inlet cowl of engine No 1 was inspected and the gas path of the core engine washed. A subsequent engine run-up (in idle) did not reveal any findings.

The work order descriptions the BFU received showed that the weekly check conducted on 20 December 2010 determined all hydraulic systems were overfilled and "IDG ENG 1 Level" was low.

The work order summary with a total of 1,233 processed work orders from 20 December 2010 to 29 January 2012 provided by the operator did not reveal any findings which might have a connection with the occurrence.

On enquiry by the BFU the operator stated that after the occurrence the Electronic Equipment Compartment (E&E) was not inspected for foreign objects, contaminations and smoke residue. Due to the technicians' description of the smell (de-icing fluid) the E&E compartment was eliminated as the originator.

1.7 Meteorological Information

The overall weather conditions were characterised by a low-pressure system above Germany with fronts moving through. In the west there were snow showers in the afternoon and evening.

Prior to departure the weather in Vienna was as follows:

19/12/2010 METAR LOWW 191850z

13011KT 8000 SCT210 M07 / M09 Q1004 R88/19//95 NOSIG=

Time: 2050 hrs (Central European Time, CET)
Wind: 130°, 11 kt
Visibility: 8 km
Weather: Not reported
Clouds: 3 to 4/8 in 21,000 ft AGL
Temperature: -7°C
Dewpoint: -9°C
Barometric air pressure 1,004 hPa
Runway condition: All runways wet, 51 to 100%, braking action good
Trend: There were no significant changes to be expected

Prior to landing, the weather in Köln/Bonn was described as follows:

19/12/2010 METAR EDDK 192020z

17009KT 8000 RASN FEW005 BKN015 01/00 Q0987 R14/190095 TEMPO 2000 SN
BKN008=

Time: 2150 hrs CET
Wind: 170°, 9 kt
Visibility: 8 km
Weather: Rain / Snow
Clouds: 1 to 2/8 in 500 ft AGL and 5 to 7/8 in 1,500 ft AGL
Temperature: 1°C
Dewpoint: 0°C
Barometric air pressure: 987 hPa
Runway condition: Runway 14: wet, 51 to 100%, contamination less than 1 mm, braking action good
Trend: Temporarily visibility 2 km with snow fall and 5 to 7/8 clouds in 800 ft AGL

The high altitude winds in the area of Köln/Bonn can be determined based on the values of the meteorological balloon which ascended in the area of Essen on 19 December 2010 at 1300 hrs and on 20 December 2010 at 0100 hrs (Appendix 2).

1.8 Aids to Navigation

The three runways at Köln/Bonn Airport had to be approached with the help of instrument approach procedures. For approaches in accordance with Instrument Flight Rules (IFR) to runway 14L an Instrument Landing System (ILS), CAT II & III

was available as precision approach procedure (Appendix 1). At the time of the approach category CAT I was active.

1.9 Radio Communications

There were radio communications between the airplane and the air traffic control units involved. The conversations were routinely recorded on a data medium but deleted after 30 days as is normal. At the time of the initiation of the investigation the recordings were, therefore, no longer available to the BFU.

1.10 Aerodrome Information

Köln/Bonn Airport (EDDK/CGN) is located about 8 NM (about 15 km) south-east of Cologne centre.

Airport elevation is 302 ft AMSL (92 m above sea level). The airport has two parallel runways oriented 136°/316°. They are 3,815 m and 1,863 m long and 60 and 45 m wide, respectively. A third runway is 2,459 m long and 45 m wide and oriented 063°/243°. The two parallel runways are asphalt runways and the other is a concrete runway.

1.11 Flight Recorders

The airplane was equipped with a Flight Data Recorder (FDR) and a Cockpit Voice Recorder (CVR). Both recorders were not seized after the occurrence.

Operators are required by aviation regulations to analyse flight data on a regular basis (FODA) as part of the operative control. The data of the approach collected for this purpose using QAR were made available to the BFU who analysed them.

1.12 Wreckage and Impact Information

1.12.1 Determinations on the Aircraft

After the landing the operator's maintenance organisation inspected the airplane. The maintenance personnel stated that even 15 minutes after the airplane had been parked the strange smell was still noticeable even with the windows open. The technicians estimated it was highly likely caused by de-icing fluid. The technicians definitely ruled out oil, fuel and electrical smell.

On 20 December 2010 the following actions were carried out on the airplane:

- Cooling fans for the cockpit instruments were replaced; contamination was not found
- Engine No. 1: Air intake was checked (negative), the inside of the core engine was washed, ground test in idle was conducted (no smell in the airplane)
- Oxygen masks in the cockpit were replaced and the crew oxygen system was maintained
- Engine ground test in accordance with the maintenance manual was conducted (no smell in the airplane)

A maintenance flight of 45 minutes was conducted which determined no findings. Afterwards it was cleared for service and four additional scheduled services were conducted on that same day.

Between 29 January and 2 February 2012, more than 13 months after the occurrence, the airplane underwent a C-Check as part of the maintenance program. During a C-check the aircraft structure is inspected in detail and tests of the systems are conducted

The conducted technical inspections of the environmental control systems including wiring and outlet nozzles and different engine test runs did not reveal any causes for the appearance of strange smells.

The flight safety department of the operator conducted an investigation of the occurrence.

1.12.2 Airborne Particles in the Atmosphere

In general, because the approach path of the aircraft passed chemical plants it cannot be ruled out that accumulation of substances was present in the air which entered the airplane through the ECS.

The subsequent enquiry with the Ministerium für Bauen, Wohnen, Stadtentwicklung und Verkehr des Landes Nordrhein-Westfalen (state ministry of North Rhine-Westphalia) did not reveal any indication of a possible contamination of the air the aircraft passed.

1.13 Medical and Pathological Information

1.13.1 History

Because the crew had declared emergency during the approach the fire brigade was notified and therefore ambulances were present.

At the parking position, the officer-in-charge of the fire brigade entered the cockpit and enquired about the health situation of the crew. Before the passengers had disembarked the paramedics helped the co-pilot into the ambulance. The PIC remained in the airplane, addressed the passengers and organised further proceedings.

The co-pilot's blood oxygen level (SPO₂) was determined while he was still in the ambulance. The co-pilot reported it was below 80%. He had received this information during a conversation with the paramedics and later compiled a report from memory. The written report of the paramedics showed a blood oxygen level of 99%.

The PIC entered an ambulance after the passengers had disembarked. Before doing so, he had been interviewed by the officer-in-charge of the fire brigade and the BFU Airport Representative. He had also filled in the Air Traffic Order Para 5 reporting form (LuftVO § 5). He later stated in an interview conducted by the BFU that his blood oxygen level had also been below 80%. The written report of the paramedics showed a value of 99%.

Both pilots received oxygen in the ambulance and after an initial enquiry regarding their health situation were taken to the hospital in Porz for further diagnoses. During the interview conducted by the BFU the PIC stated that according to his recollection he felt continuously better on the way to the hospital. He had had the impression he could finally think clearly again. He remembered the statement of one of the paramedics that the improvement was due to the oxygen and the increased blood oxygen level.

In the hospital both pilots were examined and released after about two hours. Blood and urine tests were not made.

Both pilots took a taxi back to the airport and then used their own cars to drive to the co-pilot's apartment. After debriefing the PIC wrote the report for the operator's flight operations.

The next day, 20 December 2010, the co-pilot once again went to the hospital to get another examination. He stated that his organs and the blood gas were normal; the blood parameter Creatine Kinase (CK) had been extremely high.

The co-pilot remained unfit to fly until 10 July 2011. He stated that until about five weeks after the occurrence he was not physically able to work. Then he suffered from post-traumatic stress disorder.

After he learned about the high Creatine Kinase value he recommended the PIC should go to the hospital again too. The PIC stated no unusual examination results were determined. The blood parameters were also within normal range.

The PIC resumed flight duty on 24 December 2010.

1.13.2 Statement of the Medical Expert

In order to assess the possible causes for a health impairment of the crew, the BFU asked the Flugmedizinische Institut der Luftwaffe, Rechtsmedizin und Flugunfallmedizin German Airforce Institute of Aerospace Medicine (Forensic Medicine and Medical Investigation of Aircraft Accidents) for an expert opinion.

The medical assessment was based on the following: The factual information of this emergency landing, statements in doctor's reports regarding the treatment in the hospital in Porz and blood parameters. Taken into account were the following statements the pilots had made:

Pilot in Command (PIC):

- Suddenly occurring strong prickling in hands and feet
- Swooning
- Abrupt limitation of the field of vision
- Severe dizziness
- Fear, to lose control of one's body
- Feeling sick throughout the entire approach
- "... mit dem manuellen Fliegen mit dem Flight Directory an der Obergrenze" (... being at the upper limit flying manually with the flight director)

Co-pilot:

- Suddenly occurring severe nausea
- A feeling as if someone had punched you in the stomach
- Numbness in arms and legs
- Massive sensation of drunkenness in the head
- "nicht mehr in der Lage ... zu fliegen" (No longer able ... to fly)
- Scanning the instruments is strenuous
- Difficulties to concentrate
- Impaired ability to think
- Fear
- Difficulties to don the oxygen mask

For the co-pilot the anamnestic indication of 20 December 2010 was taken into account that he might have inhaled smoke gas and had carried out excessive athletic sports and gone skiing a lot (Note: Prior to 19 December 2010). The examination results were normal except for the muscles (Musculus pectoralis major and Musculus triceps) which were sensitive to pressure on both sides.

The consultation on 20 December 2010 resulted in the diagnosis "Traumatic muscle damage ..." and the consultation on 21 December 2010 in "Traumatic muscle ischemia ..." and "Toxic effect of gas, fumes or smoke ..."

Relevant blood parameters were:

Examination	Value on 20 Dec 2010	Value on 22 Dec 2010	Reference Range
Creatin Kinase (CK)	26,804 U/l	18,296 U/l	up to 190
CK-MB	270 U/l	287 U/l	< 25
LDH Lactate dehydrogenase	1,076 U/l	595 U/l	up to 250
GOT (AST)	461 U/l	421 U/l	up to 50
GPT (ALT)	111 U/l	141 U/l	up to 50

Additional blood parameters, including haemogram and electrolytes, did not show any pathological results.

Assessment of the expert:

The expert opinion of the German Airforce Institute of Aerospace Medicine raised the question of the so-called "aerotoxic syndrome".

The possibility of toxic gas inhalation (smoke gas and/or de-icing fluid) in the cockpit was taken into differential diagnostic deliberations because the experts did not have results of technical or flight toxicological inspections which may have been conducted available.

The expert stated that not having all the information, the described symptoms could be in accord with the inhibition of the enzyme Acetyl cholinesterase or other neuro-specific esterase which may be caused by organophosphate, especially Tricresylphosphate and its isomers.

After differential diagnostic deliberations other causes could be taken into consideration but the experts think them rather unlikely or rule them out. Considered were:

- Acute exposure to carbon monoxide (CO)
- Inhalation of de-icing fluid
- Contamination of the breathable air through insecticides
- Lack of oxygen
- Cardiological disease
- Noxa ingested via food or drink (e.g. food poisoning)

The expert opinion does not draw a connection between the occurrences in the cockpit and the pressure sensitivity of the *Musculus pectoralis major* and *Musculus triceps* on both sides and the muscle ache the co-pilot felt. The expert opinion comes to the conclusion that these are the sole result of the excessive athletic sports of the previous days. According to the expert opinion the increased blood parameters fit this cause very well.

The expert opinion makes references to literature describing muscle necrosis following very severe poisoning with organophosphate compounds. The increase in CK blood parameters was inevitable and so was the muscle weakness lasting for

weeks. A connection with the events in the cockpit was ruled out because the co-pilot did not mention any muscle aches on other muscles.

The expert opinion ruled out intoxication with organic solvents which can cause an increased CK blood parameter because there were no sufficient anamnestic indications.

In summary, the expert opinion draws the conclusion that the symptoms described by the pilots and the examination findings are not sufficient to relate them to an "aerotoxic syndrome".

Due to the differential diagnosis the experts discussed other causes because they result in similar symptoms; e.g. the lack of oxygen determined for both pilots as singular event, but also a singular exposure to carbon monoxide (CO) or the contamination with insecticides.

The expert opinion does not draw a causal connection between the increased muscle-specific blood parameters and the occurrence during the flight. The assessment was that these values originated from the excessive athletic sport.

The expert opinion states there are no indications that the increased muscle-specific blood parameters were caused by intoxication via the breathable air in the cockpit.

The expert opinion of the German Airforce Institute of Aerospace Medicine was confirmed by a statement of a toxicologist. In addition, the BFU has asked a specialist in internal medicine to assess the blood tests.

1.14 Fire

There was no fire.

1.15 Survival Aspects

Not applicable

1.16 Tests and Research

None

1.17 Organisational and Management Information

The aircraft was operated by an air operator according to Commission Regulation (EC) No 1008/2008. At the time of the occurrence the Air Operator Certificate (AOC) showed a total of 30 transport aircraft; all of them were Airbus A319.

1.71.1 Procedures for Smell and/or Smoke Events

The operator's Operating Manual OM-B and the Quick Reference Handbook (QRH) stipulated actions in the form of checklists in case of smoke and/or smell development.

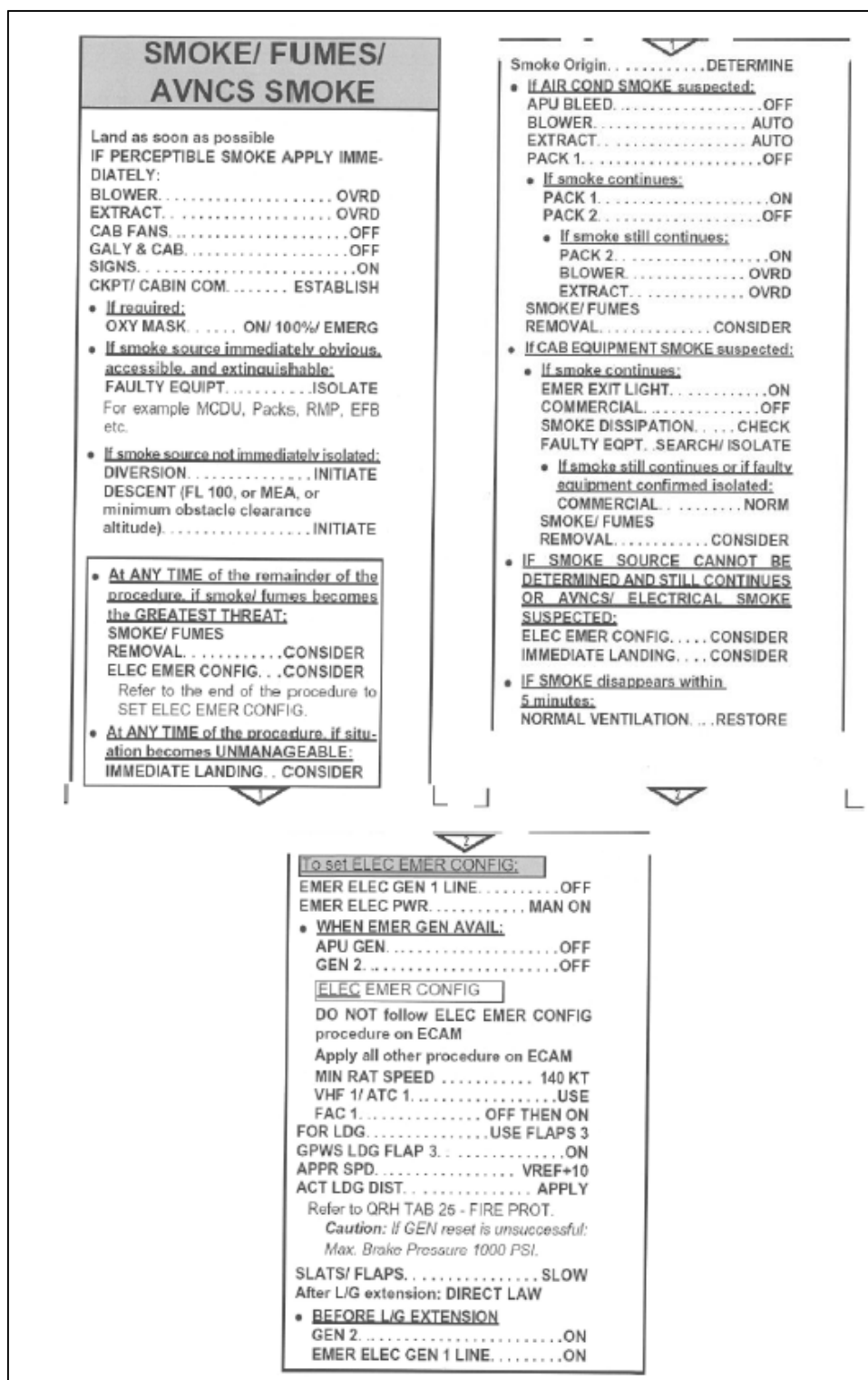

To set ELEC EMER CONFIG:

EMER ELEC GEN 1 LINE OFF
EMER ELEC PWR MAN ON

- WHEN EMER GEN AVAIL:
APU GEN OFF
GEN 2 OFF

ELEC EMER CONFIG

DO NOT follow ELEC EMER CONFIG procedure on ECAM
Apply all other procedure on ECAM
MIN RAT SPEED 140 KT
VHF 1/ ATC 1 USE
FAC 1 OFF THEN ON
FOR LDG. USE FLAPS 3
GPWS LDG FLAP 3. ON
APPR SPD. VREF+10
ACT LDG DIST. APPLY
Refer to QRH TAB 26 - FIRE PROT.
*Caution: If GEN reset is unsuccessful:
Max. Brake Pressure 1000 PSI.*

SLATS/ FLAPS. SLOW
After L/G extension: DIRECT LAW

- BEFORE L/G EXTENSION
GEN 2 ON
EMER ELEC GEN 1 LINE. ON

Image 8: Checklist Smoke / Fume / Avionic Smoke

Source: OM-B



SMOKE/ FUMES REMOVAL	
EMER EXIT LIGHT.....	ON
<ul style="list-style-type: none"> • <u>If fuel vapor:</u> 	
CABIN FANS.....	ON
PACK 1+2.....	OFF
<ul style="list-style-type: none"> • <u>If no fuel vapor:</u> 	
CABIN FANS.....	OFF
PACK FLOW.....	HI
<i>Note:</i> - Do not shut down air-conditioning packs or reduce ventilation in an attempt to smother the fire. - Do not deploy oxygen masks if fire is suspected in the cabin.	
LDG ELEV.....	10 000 FT OR MEA
Descent (to FL 100 or MEA or minimum obstacle clearance altitude).....	
ATC.....	INITIATE
SMOKE/ FUMES/ AVNCS	
SMOKE PROC.....	CONTINUE
<ul style="list-style-type: none"> • <u>At FL 100 or MEA:</u> 	
APU MASTER SW	
(if in ELEC EMER CONFIG).....	
PACKS 1 + 2.....	OFF
MODE SEL.....	MAN
MAN V/S CTL.....	FULL UP
RAM AIR.....	ON
APU MASTER SW.....	OFF
<ul style="list-style-type: none"> • <u>If smoke persists, cockpit window opening:</u> 	
<i>Note: Unless the smoke is in the cockpit do not open cockpit window to evacuate the smoke.</i>	
	
	
MAX SPD.....	200 KT
COCKPIT DOOR.....	OPEN
Headsets.....	ON
PNF COCKPIT Window.....	OPEN
<ul style="list-style-type: none"> • <u>When window is open:</u> 	
NON-AFFECTED PACK(s).....	ON
VISUAL WARNINGS	(noisy cockpit).....
	MONITOR
<i>Caution: Due to increased noise level pay particular attention to visual warnings.</i>	
SMOKE/ FUMES/ AVNCS	
SMOKE PROC.....	CONTINUE

Image 9: Checklist Smoke / Fume Removal

Source: OM-B

1.17.2 Use of the Oxygen Masks

In the cockpit the Airbus A319 is equipped with an oxygen system.

Through the oxygen mask each flight crew member can receive a mixture of air and oxygen (Normal) or 100% oxygen depending on the setting.

According to the OM-B (Rev. 15 November 2010) the cockpit crews are required to don their oxygen masks whenever the situation requires it. The following cases are explicitly listed:

- Loss of pressure
- Use of fire extinguishers

- Contamination of the air, e.g. smoke
- Fumes or smells (cockpit or cabin)

If the air in the cockpit is contaminated 100% oxygen is to be used.

The operator stated use of the oxygen masks is regularly trained in the simulator.

1.18 Additional Information

1.18.1 Reporting Procedure

At 2140 hrs, the airplane reached the parking position after the occurrence during the approach.

Immediately after the landing, Köln/Bonn Airport informed the BFU by telephone about the occurrence. The BFU deployed a BFU Airport Representative to investigate the situation and to gather information for the decision making process on how to proceed. The BFU Airport Representative stated he was about 25 minutes after he was alarmed at the airplane and found that all passengers had already disembarked. He stated the PIC was still in the cockpit.

On enquiry, the PIC reported a smell development had occurred and right now he did not have any physical problems. The BFU Airport Representative stated he had had the impression the physical condition of the PIC and his health seemed normal and did not show any abnormalities.

The BFU Airport Representative could not detect any unusual smells in the cockpit. The officer-in-charge of the fire brigade, who entered the aircraft right after it reached the parking position, did not notice any unusual smells either.

The BFU Airport Representative stated that the Air Traffic Order Para 5 reporting form the PIC had filled in was sent via fax to the BFU and on request of the PIC also to the operator. The investigator on duty at the BFU never received this Air Traffic Order Para 5 reporting form sent by fax. The reason could not be determined.

On the same day at 2332 hrs, the Landesamt für Zentrale Polizeiliche Dienste Nordrhein-Westfalen (LZPD NRW) (police state office) informed the BFU via fax about the occurrence. The fax contained the information that an Airbus A319 with 160 persons aboard coming from Vienna had reported smoke in the cockpit and the

two pilots had been taken to the hospital in Porz by ambulance with the suspicion of smoke gas intoxication.

The next morning the investigator on duty contacted the head of operations of the operator. He learned that it was not smoke but smell and the crew had been released from the hospital. The maintenance organisation would check the airplane and send a report to the BFU.

On 20 December 2010 (ante meridiem) the operator reported the occurrence to the BFU and the Luftfahrt-Bundesamt (German civil aviation authority, LBA) using the on-line Air Traffic Order Para 5 reporting form. The report gives the statement of the PIC (Translation):

"During the turn to the base leg the CM 1 noticed a rather strong, disagreeable smell which the CM 2 confirmed right away. Our first impression was that the smell was electrical burnt. Immediate enquiry with the cabin determined that nothing was smelled there. In the meantime, the smell seemed to have lessened but was still noticeable. A few seconds later the turn onto final occurred. At the same time CMS said he felt severe indisposition and CM1 noticed adverse effects on his perception and prickling in the extremities of both CMs occurred. The oxygen masks were donned immediately and ATC informed that we change to the tower frequency because in the meantime we had become established on final course. CM2 declared emergency during the initial call with the tower and the approach was continued with donned masks. The landing occurred without incidents. After the landing exit A3 was used and accompanied by the fire brigade which had been called on frequency 123.1 we taxied to the terminal. The circumstances were explained to the fire brigade and after a short consultation it was decided to taxi to position A07. On the way the cabin crew was informed and briefed as to the further course of events.

At the position we opened both windows and after we had removed the masks CM1 had made a soothing announcement to the passengers which up until that moment had not had any idea about the emergency. The fire brigade entered the airplane before the passengers disembarked which was explained with another short announcement. CM2 was treated in the ambulance due to continuing severe indisposition. In agreement with the fire brigade the passengers disembarked. Then a debriefing with the cabin

crew was conducted. It was enquired about their perception and the CISM support pointed out.

After the BFU investigator on duty received this report he once again established contact with the operator and learned that maintenance estimated the smell originated from de-icing fluid. A conducted ground test had come out negative and the crew involved did not have any symptoms of poisoning. This information was brought to the daily BFU meeting and it was decided it did not meet the criteria for further investigation.

Approximately one year after the occurrence, the BFU received new information which led to the initiation of an investigation in accordance with Commission Regulation (EC) No 996/2010 and the Law Relating to the Investigation into Accidents and Incidents Associated with the Operation of Civil Aircraft (FIUUG). This information resulted in an interview with the pilots.

After the Interim Report had been published the BFU received information regarding the content of the Air Traffic Order Para 5 reporting form which the BFU Airport Representative had send via fax the evening of the occurrence and which the BFU never received.

In this report the PIC had given formal information and described the event as follows (Translation):

During the approach we noticed a strong unfamiliar smell in the cockpit. On enquiry, the cabin reported no smell was noticeable there.

Shortly afterwards both pilots showed strong physical reactions in the form of nausea and dizziness. Oxygen masks were donned immediately and emergency declared. Landing occurred four minutes later without incident.

The fire brigade followed us to the parking position, where the passengers disembarked after a short inspection.

The co-pilot received medical treatment. At no time was there smoke visible. The pilot also received medical treatment. Both were taken to the hospital in Porz for further clarification.

1.18.2 Physiological and Psychological Effects of Smell

In 2005 the Bayerische Landesamt für Umwelt (Bavarian state office for the environment) had published the documentation "UmweltWissen" with the topics "Gerüche und Geruchsbelästigung" (smell and odour nuisance).

Among other things, the documentation described the physiological and psychological effect as follows (Translation):

[...]

Physiological and psychological effects

Smell stimuli act as signal for increased attention. Thus, smells trigger physiological reactions. Whenever they trigger "alarm signals" they activate the organism. They cause, for example, stress which prepares the body for flight or fight reactions such as dilation of the pupils or contraction of the peripheral blood vessels.

Nuisances, i.e. psychological effects, are the most important category. In general, a slight and rather displeasing odour is much less disturbing than a strong and disagreeable one. Personal characteristics such as age, satisfaction with ones health or the way one handles stress can either significantly increase or decrease the reaction to the nuisance. For larger groups of persons the frequency of the odour is a good indication for the annoyance. This is often investigated whenever the annoyance level of residents by odour emission of industrial plants is to be judged.

Odour nuisance often triggers fear of pollutant loads which are toxicologically unfounded. If odours are viewed as danger they can trigger anxiety, fear and aggression. Then a serious health hazard can develop.

With the so-called Toxicopy the patients develop a disease pattern or pathological symptoms which are typical for intoxications but without the respective poison being present. The patients interpret odour as indication for an impending intoxication and react, for example, with vomiting but sometimes even with specific reactions. Therefore, odours can indeed have an ill effect on health without being toxic.

So far, no direct pathogenic effect of odours was proven. Not even with toxic substances does the perception of odours reliably reveal whether or not a toxic effect is to be expected [...]:

Human beings notice concentrations of most of the odour-emitting poisons or pollutants which are not yet harmful or lethal. One example is hydrogen sulphide, which can be smelled in very small quantities when it is not yet lethal. When the dose becomes lethal, however, it is odourless for humans.

A lot of toxic air pollutants are odourless, e.g. carbon monoxide.

Some compounds are expected to have an ill effect on one's health in concentrations in the odour threshold range such as Acrolein, Chloroform, p-Dichlorobenzene, 1,1,1-Trichlorethane and Ozone [...].

[...]

1.18.3 Aircraft History

On 27 May 2008 an incident occurred aboard the same Airbus A319 after take-off in Dublin, Ireland, which the Irish Air Accident Investigation Unit classified and investigated as Serious Incident (AAIU Report No 2010-008). During the climb the purser informed the PIC that something was happening because almost all passengers had fallen asleep and the cabin crew member closest to her did not seem to be responsive. And she did not feel well herself. Because the PIC seemed to determine an unusual symptom on him, the pilots decided to don their oxygen masks, declare emergency and return to Dublin. During the subsequent interview all cabin crew members stated they had felt very tired and unwell after take-off. Some of the passengers, mostly elderly people, stated they had felt sleepy. None of the passengers complained about feeling unwell or experiencing loss of sensation.

The Dublin Airport Fire Service completed an air composition check using a Crowcon Gas detector. This detector did not show any unusual values for a variety of gases including methane (CH₄), hydrogen sulphide (H₂S), carbon monoxide (CO) and oxygen (O₂).

During the next few days extensive technical checks on the aircraft were conducted but no indications of system or component conditions were found which could be the cause for the observations reported aboard. Special attention was paid to the possible contamination with oil from the engines or the APU.

At one point during these tests, two members of the inspecting team reported a strong smell in the cabin. However the other 13 members of the team reported nothing unusual.

After three days of testing it was decided that the aircraft be flown to the manufacturer's facility at Toulouse, France, for further tests. The flight to Toulouse was flown, unpressurised, at 10,000 ft. The extensive tests in Toulouse lasted for six days and did not reveal any causes and so it was decided to return the airplane to scheduled services.

The AAIU comes to the conclusion that "The probable cause of the adverse symptoms reported by the aircraft crew and some passengers could not be determined."

1.19 Useful or Effective Investigation Techniques

1.19.1 Determination of Flight Parameters from QAR Data

The spatial and chronological course of the flight was reconstructed using QAR data recordings. The data contained the recorded positions (geographical longitude and latitude) and the pressure altitude; both were recorded every second. The sequence of this three-dimensional location described a course of flight by approximation.

The deviation from the extended runway centre line during the ILS approach was calculated by a computed comparison of the guide beams for the course and the glideslope. The deviation was computed into "Dot indication".

The ground speed of the airplane for each distance between two consecutive positions was calculated from the distance flown between these two positions and the time difference of one second.

2. Analysis

2.1 General

The occurrence of 19 December 2010 on the flight from Vienna to Köln/Bonn Airport with a massive odour development in the cockpit and a subsequent impairment of the performance capacity of the two pilots (partial incapacitation) was to be classified as Serious Incident in accordance with Commission Regulation (EC) 996/2010 and the Law Relating to the Investigation into Accidents and Incidents Associated with the Operation of Civil Aircraft (FIUUG).

The classification as Serious Incident and the initiation of an investigation started one year after the occurrence. On the evening of the day of the occurrence the BFU had been informed. Due to an error in communication within the BFU the seriousness of the occurrence had not become clear. About one year later the BFU became aware of the importance of this occurrence due to new information. At the time the investigation was initiated, important evidence such as the CVR, radar and radio communications recordings were no longer available. Thus the investigation was essentially based on statements of the crew, on QAR data the operator provided, the analysis of maintenance documentation and analysis of aircraft systems using the documentation of the aircraft manufacturer.

For the BFU the severity of the occurrence was characterised by the impairment of the performance capacity of both pilots. An essential aspect of the analysis was to what extent the flight crew was still able to conduct a stabilised approach and how effective were intended safety measures such as oxygen masks.

Another key aspect of the analysis was the question how both pilots could get into this situation. The question also arose whether the Serious Incident was connected to the so-called aerotoxic syndrome which is often discussed in the aviation industry and the media. For the clarification of this question external expert opinions and external medical and psychological expertise were taken into account.

For the last several months the BFU has been receiving numerous reports concerning so-called fume events and in comparison to these, the BFU has classified this occurrence as relevant for aviation safety. The reports concerning fume events show a broad spectrum: determination and observation of odours and smoke, impairment through eye and nose irritations, headaches or limitations of the crew's capability to act (Incapacitation) or long-term health impairment.

According to the Commission Regulation (EC) 996/2010 and the Law Relating to the Investigation into Accidents and Incidents Associated with the Operation of Civil Aircraft, the BFU can only investigate cases relevant for aviation safety. These include fire or smoke on board, occurrences which force the flight crews to don their oxygen masks and any flight crew incapacitation during the flight. Observation of odours, or smoke, irritations or headaches only becomes part of an investigation if they originate from fire or incapacitation.

Reports of persons who state they ascribe their long-term impairment to contaminated cabin air can be investigated only to a limited extent within the scope and the available means of aircraft accident investigation. The mode of operation of the BFU, as well as any other air accident investigation authority, is such that due to a concrete occurrence, facts are determined which allow assessment of the causes. This means that by events dating back a while investigation is rarely possible because data is only available for a limited time span.

Independent of this, occurrences where there is no obligation to report or which will not be investigated by the BFU are assessed by the operator in the scope of quality assurance and, if applicable, investigated by the operator.

2.2 Analysis of the Flight from the Operational Viewpoint

The recorded QAR data which was analysed by the BFU did not reveal any indications of abnormalities during the cruise flight and the descent for the approach to Köln/Bonn Airport.

The speed of the airplane was too high when it intercepted the glideslope of the ILS; the PF noticed this and corrected it several times. After the speed brakes and the landing gear were extended, the PF asked the PNF to set the flaps in position 2. He had opted for this sequence because before the speed had still been too high to set the flaps in position 2.

During the entire approach the runway heading did not show any abnormalities. The glidepath did not show any instability. The determined short-term deviations from the glidepath by about 8 - 7 NM and 5 - 3.5 NM prior to touch-down were very likely due to the change in configuration (flaps, landing gear) and speed.

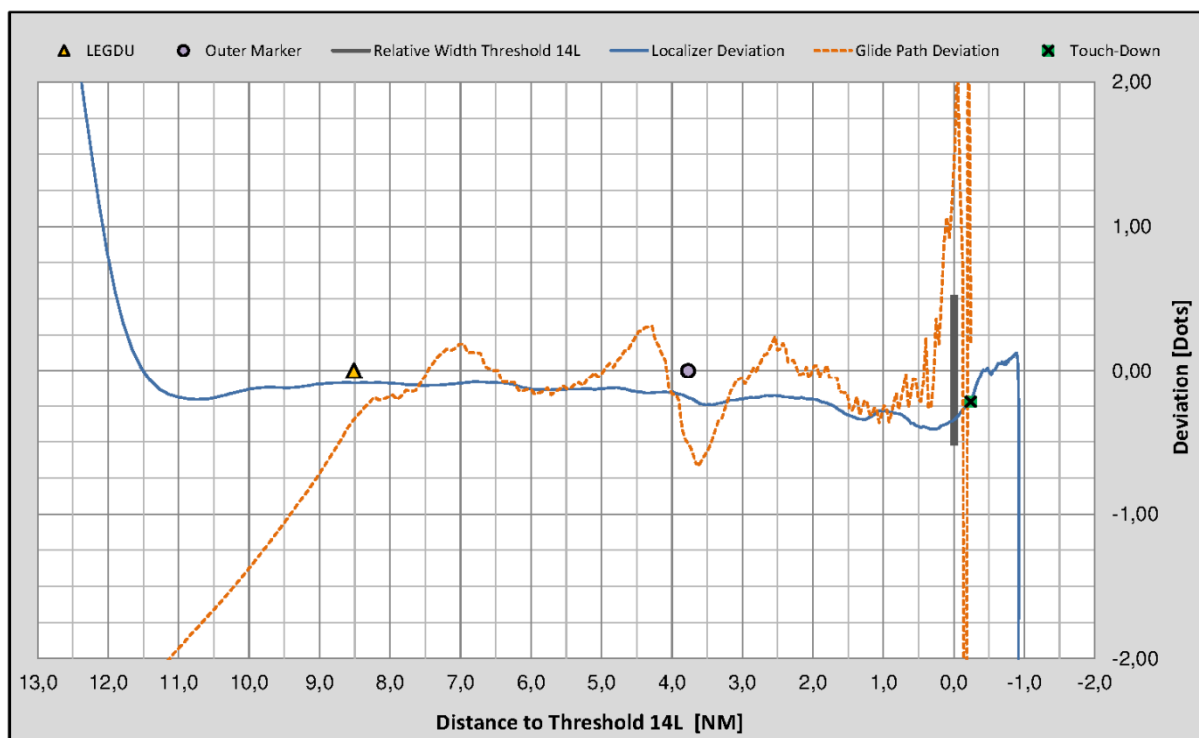

Image 10: Deviation from the runway heading and the glidepath

Source FODA data / BFU

With hindsight the PF's decision to fly the approach manually did not have any negative effect on the safe conduct of the flight.

The airplane was in the required landing configuration.

The analysis of the QAR data showed that the airplane had a ground speed of approximately 135 kt while passing 1,000 ft. In the subsequent 50 seconds the ground speed decreased by 10 kt.

The BFU is of the opinion that the criteria stipulated in the OM-A regarding the adherence to the flight path were met when the airplane passed this altitude.

Because some influencing factors such as wind conditions and divergence from the standard atmosphere were not available it was impossible for the BFU to calculate the indicated airspeed from the ground speed.

An assessment if the indicated airspeed met the criteria for a stabilised approach (+10 kt, -5 kt) while passing 1,000 ft was only possible to a limited extent.

Because the touchdown occurred in the normal area of the runway and the fact that the airplane could leave the runway after about 1,600 m indicated that the speed during short final and touch-down was adequate.

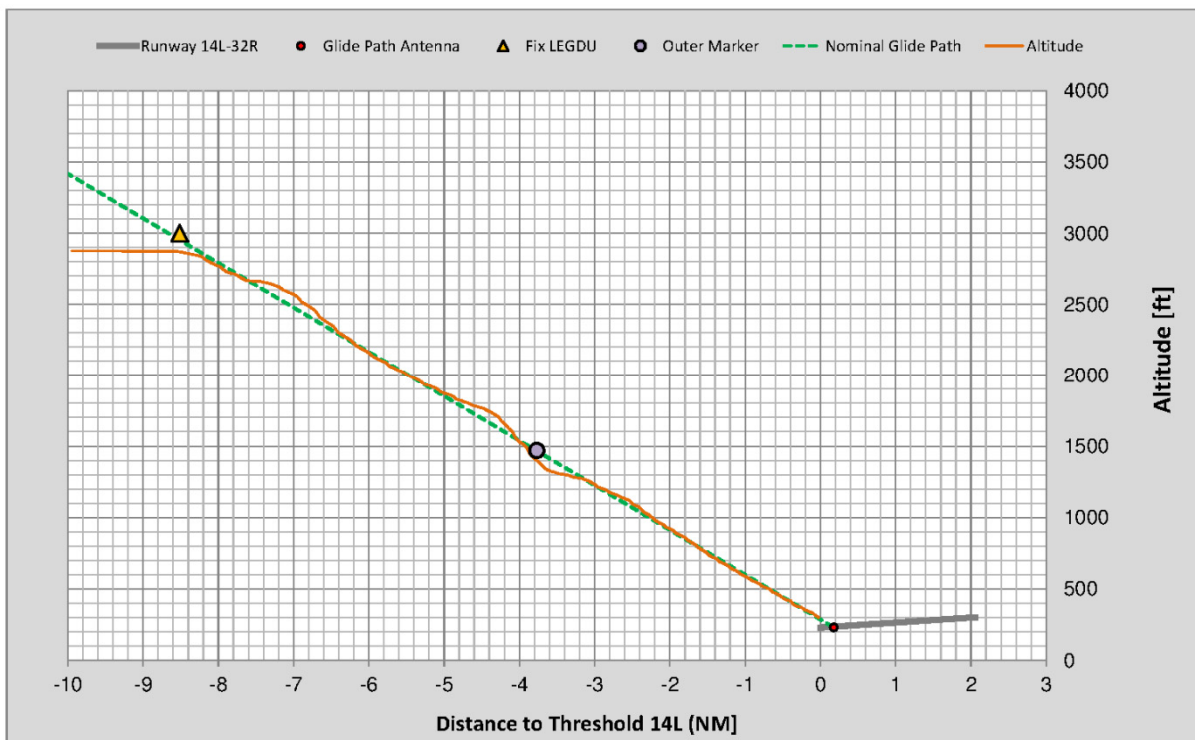

Image 11: Approach as vertical profile

Source: FODA data / BFU

There were no unusual heading fluctuations during the braking and roll out. Initially the airplane was braked with the autobrake and then manually in a common fashion. It rolled off at the usual taxiway A3.

The radio communication with the fire brigade was conducted in accordance with procedures. During taxiing the PIC temporarily handed over the controls to the co-pilot.

The flight crew could follow the follow-me vehicle to the parking position. Neither the flight crew, nor the fire brigade, nor the aircraft marshaller saw the need to park the airplane in the emergency parking area in front of the fire station.

2.3 Specific Conditions

2.3.1 Crew

Both pilots were properly licensed and qualified to conduct the flight.

The PIC had a total flying experience of 8,535 hours; 7,864 hours of which on airplanes with a take-off mass of more than 20 t and 3,107 hours on the type and was therefore highly experienced.

The co-pilot was relatively inexperienced, having a total flight time of 720 hours with 427 hours on the Airbus A319. However, this was commensurate with his age and stage of career. At the time of the occurrence, he had successfully completed a course of education and training for employment in line operations.

On the day of the occurrence both pilots had been on duty for nine hours and had before been off duty for 14 hours. This is not unusual and was within the stipulations of aviation regulations. However, the assessment of the Serious Incident had to take into consideration that, at the time of the occurrence, the capability to perform and react might have been slightly reduced due to the hours on duty in combination with winter operations. For the co-pilot the flight time already flown that day and then the suddenly occurring incident had been a larger challenge due to him having less flight time and professional experience.

The flight attendants were not directly affected because the odour development did not occur in the cabin or was not noticed.

2.3.2 Weather

The weather that day was typical for winter operations. While the weather in Vienna was rather good, the weather in the area around Köln/Bonn was characterised by snow fall during the afternoon and evening so that take-off in Vienna was delayed by three hours. While the aircraft was on the ground in Vienna, Köln/Bonn Airport was closed several times due to snow. The crew awaiting departure in Vienna was continuously informed of the weather conditions in Köln/Bonn. From the descriptions of the crew, the BFU gained the impression that there had been a constant exchange with the operations centre in Köln/Bonn and no one had pressurised the crew in any way. In addition, the crew was burdened with information due to the continuous

information search about the weather, the take-off delay for Köln/Bonn, the decision making process and the provisions for the waiting passengers.

For the landing in Köln/Bonn the METAR from 2120 hrs was available. In relation to the overall weather situation, the cloud bases of 1 - 2/8 in 500 ft AGL and 5 - 7/8 in 1,500 ft AGL with rain/snow fall and an indicated visibility of 8 km did not pose a special challenge for the crew. The category CAT I active for runway 14L at the time of the landing did also not indicate any unusual landing conditions

With the exception of the higher work load and increased tension due to winter operations, the weather did not have a direct effect on the Serious Incident during the approach to Köln/Bonn Airport.

2.3.3 Aircraft De-Icing

Having the aircraft de-iced prior to take-off in Vienna was appropriate given the weather and temperature.

As far as the BFU could discern from the descriptions the pilots had given, there were no abnormalities during the de-icing procedure in Vienna or pressure for time which might have had an effect on the course of the flight.

2.4 Human Performance

2.4.1 General Co-Operation and Working Atmosphere

From the interviews and the written descriptions of the two pilots the BFU gained the impression that the task distribution in the cockpit was clearly arranged and both crew members worked responsibly and effectively as a team.

The PIC carried out his role as superior, manager and pilot flying on this leg from Vienna to Köln/Bonn, whereas the co-pilot carried out his tasks independently. The necessary mutual monitoring was also given. Prior to take-off in Vienna the slot threatened to run out and the de-icing procedure was still pending, so, for a short time, hectic occurred in the cockpit and the co-pilot requested in a polite but firm voice the adherence to the sequence of checklists. The PIC mentioned this situation to the BFU and described it with the words "... und dann waren wir wieder in der Sequenz" (and then we were once again in sequence).

From the interviews an optimal trans-cockpit authority gradient (Hawkins)⁴ between PIC and co-pilot became apparent. In face of his higher ranking in the professional hierarchy, the PIC listened to and appreciated the co-pilot's opinion. On the other hand, the co-pilot accepted the professional position and experience of the PIC.

Both pilots confirmed that a pleasant and relaxed working atmosphere prevailed in the cockpit. For the pilots this was their second flight together. From the interviews with the pilots the BFU could deduce that the interpersonal level was characterised by appreciation and mutual respect.

2.4.2 Odour Development in the Cockpit and the Handling of the Situation

Due to the odour development in the cockpit, the normal and routinely completion of tasks and the co-operation in the cockpit changed on the base leg to runway 14L. Even if the cruise flight from Vienna to Köln/Bonn had been a matter of routine, the approach posed more of a stress for both pilots because of the winterly weather. In addition, there was an increase in work load due to the impending landing and then the crew noticed the smell. Briefly there was a phase of insecurity because it was not clear whether the smell would subside again or if it would eventually increase. The enquiry with the purser whether or not the odour was noticeable in the cabin shows the PIC thought the smell important and had already begun to mentally search for the source. The pilots stated that for a short time it seemed the smell had decreased which initially released the tension.

A few moments later the situation in the cockpit escalated. The statement of the co-pilot that he felt seriously sick, his arms and legs became numb and he could no longer think clearly described the seriousness of the situation. The decision to don the oxygen masks was congruent.

The PIC also reported massive symptoms which was important both for the assessment of the situation in the cockpit in regard to the continuation of the flight with the subsequent landing and for the determination of causes. The reported symptoms such as severe prickling in hands and feet, limitation of the field of vision and severe dizziness indicated a significant impairment of his performance capabilities and similarities with the co-pilot's symptoms.

⁴ PIC F. Hawkins, Human Factors in Flight, Ashgate Publishing, Aldershot, UK, 1987

The indication that both pilots may have suffered incapacitation or at least severe impairment of performance capabilities was, for the BFU, of significant safety relevance. It had to be assumed that not only the redundancy of two pilots might no longer be given but that maybe important and safety-relevant actions could no longer be performed by the pilots. Key aspects of this analysis were actions of pilots which cannot be carried out by technical systems.

The only source of information the BFU had, were the QAR data and the descriptions the two pilots had given, because neither CVR data, nor video recordings, nor witness reports were available. The pilots have assessed the severity of their physiological and psychological limitations with the help of a description and decision-making aid (Chapter 1.2).

The classification the PIC made of "Impairment" to "Partial Impairment" showed that he could perform his tasks with some, partially even great difficulties and that he made some minor errors. One example was that the landing checklist was completed after the pilot monitoring had reminded them to do so.

The co-pilot described the impairment of his performance capabilities as "Partial Incapacitation" which means he could carry out his tasks with great difficulties only.

In summary, the BFU has come to the conclusion that neither of the two pilots suffered "full" incapacitation. However, both were significantly impaired in their capacity to perform. The co-pilot was more gravely affected than the PIC.

This assessment was confirmed by the analysis of the course of the flight between the beginning of the occurrence and the parking of the airplane at the parking position. In spite of severe limitations the crew was able to bring the flight to an end in a controlled fashion.

2.4.3 Making Use of Available Resources

The BFU gained the impression that until the beginning of the occurrence the Standard Operating Procedures (SOP) were adhered to. It became also apparent that Crew Resource Management (CRM) had been defined in the operator's flight operations and was put into practice by the crew during the flight from Vienna to Köln/Bonn.

The crew had to reorganise the team work once the occurrence happened. One difficulty was to recognise the remaining capability to act of the other pilot. Even

though communication was possible after the oxygen masks had been donned and the situation had obviously slightly improved, it was hard for the PIC to maintain structured co-operation with the co-pilot. In addition, his physiological and psychological capability to perform was limited.

Until the approach the flight had been demanding due to the delay and winter operations but nevertheless was a matter of routine. During the approach a stress situation arose.

The distribution of tasks had to be adapted to the situation. For example, the PIC, as PF, extended the flaps. The function of pilot monitoring could only be carried out to a limited extent.

The decision of the PIC to conduct the approach and landing manually instead of automated was noteworthy. In general, the automated conduct of flight is supposed to be a relief for flight crews which should also be true for abnormal situations.

The BFU is of the opinion that an autoland would have posed risks because the required operating conditions for the instrument landing system on the ground could not be guaranteed in the short time available.

Experienced pilots assess the question differently whether or not an approach should be conducted with the autoflight system for as long as possible. One argument for the use of the autoflight system during approach for as long as possible is the relief of the flight crew especially if one pilot suffers from incapacitation. Pilots who argue the opposite think that the manual control affords a better influence on the airplane and the flight path. The experience of the BFU is that in this question the professional career and the experience of the pilots in regard to the manual flying play a role.

The BFU is of the opinion that regarding this question there are no stipulations by the aircraft manufacturer or in the operator's OM and no standardised trainings.

The BFU does not question the pilot's decision to fly and land manually after the occurrence had happened. The justification that the situation had scared him, and he then rejected the thought to conduct an autoland pretty fast, because he would have had to consider too many things, was understandable.

When the BFU reviewed the course of action, the argument and the sense of the PIC that due to his long-term experience the control of the airplane would occur "automatisiert" (automated) were taken into consideration.

The fact that approach and landing were stabilised and safe shows that the PIC had estimated his options in this situation correctly.

The use of autobrake causing the airplane to brake automatically and then braking manually once a speed of about 40 kt was reached was appropriate to the situation and useful. Hence, it was possible to use taxiway A3. Handing controls over to the co-pilot during taxiing to talk with the fire brigade and the purser was appropriate to the situation.

The BFU is of the opinion that the co-pilot's remark after they had turned onto taxiway B that they had not completed the after landing items indicates a still existing work performance of the co-pilot and team-oriented co-operation.

The BFU regards the fact that the newly-installed frequency for the fire brigade was used as confirmation that the crew was still able to act consciously, albeit with limitations, after the landing. This also showed that the separate frequency with the fire brigade aids the swifter and improved coordination of actions.

2.5 Technical Aspects

2.5.1 Aircraft Climatic System

The principle and the procedural layout of the cockpit and cabin climate control of the Airbus A319 can be compared to other transport aircraft. The design, where engine bleed air is fed to the Air Cycle Machine (ACM) and is then mixed with some of the re-cycled air, accounts for the fact that it is always technically re-cycled air. Even though contaminations due to technical malfunctions cannot be ruled out, a safe conduct of flight has to be assured.

The BFU basically examines two technical key aspects when investigating occurrences in connection with smoke and smell development in transport aircraft:

1. Outside contamination of the ECS, e.g. contaminated bleed air, leakages or contaminated outside air.
2. Contaminations originating from within the airplane, e.g. pollution, cargo, cleaning supplies, operating errors (stoves), poisonous substances from electronic gadgets due to errors (overheated components, etc.) and vapours from parts and components.

Because air and swab samples were not available and in-depths checks of individual system components were no longer informative, the analysis had to be limited to theoretical consideration.

One key aspect was the question whether or not an intense smell development noticed in the cockpit but not the passenger cabin can be caused and explained by an analysis of the system technology.

The in-depths assessment of the system and the procedural process for the air recycling has resulted in the following explanation:

Had the air been contaminated it had reached the cockpit and the two cabin zones alike. The mixer design showed that contaminations of the air from pack 2 would have reached the cockpit only delayed and with reduced concentration. But since the smell had been observed in the cockpit first, contamination of the air from pack 2 could be ruled out.

Possible contaminations of the air from pack 1 would have reached the cockpit and the cabin.

Although due to the system design the cockpit air contained more air from pack 1 than the forward cabin, it is highly unlikely that a contamination of this airflow would not have been noticed by passengers in the forward cabin; whereas the crew in the cockpit very promptly noticed an intense odour. Because of the large number of persons in the cabin there was a diverse potential of perception.

The temperature the crew had selected and therefore the amount of trim air could no longer be determined. It could also not be determined from which engine the air was fed into the hot manifold at that time. The influence the trim air has is basically rather slight due to its low portion of the total air flow volume.

The consequences determined by the system design on the possible influencing factors of the possible air contamination were discussed in detail and described in Chapter 2.6.3.

Because of the long time between the occurrence and the investigation the BFU abstained from asking the pilots involved to undergo an olfactory test.

Even though it can no longer be determined it is very likely that there had been an odour which originated inside the airplane probably in the cockpit.

2.5.2 Determinations on the Airplane and Maintenance

The BFU has not made any determinations on the airplane which could provide an explanation for the smell development. Neither the technical inspection conducted by the operator immediately after the occurrence nor an extensive examination of the maintenance documentation conducted by the BFU has revealed any indications as to the possible cause for the smell.

Since no concrete error could be determined and the occurrence only happened once, it could be ruled out with a high degree of certainty that there was contamination due to a malfunction within the ECS or any of the connected systems.

The BFU could not determine any direct connection to the occurrence on 27 May 2008 which the Air Accident Investigation Unit in Ireland investigated. One significant difference was that during the occurrence in Ireland passengers and flight attendants complained about indisposition and limitations of sensation. The cockpit crew donned their oxygen masks as precautionary action but did not experience significant symptoms.

2.6 Assessment of Possible Influencing Factors

2.6.1 Aerotoxic Syndrome

The term aerotoxic syndrome deals with possible health impairments which might be caused by air contaminations in the cabin and cockpit of airplanes. At this time the term is neither medically nor scientifically defined. The current scientific discussion assumes a contamination of the air for passenger cabin and cockpit with partially pyrolised oil. Due to existing system leakages fumes may leak out which consist of a complex mixture of:

- Tricresylphosphate and its isomeres (TCP)
- N-phenyl-L-Naphthylamine (PAN)
- Carbon monoxide (CO)

One of the possibly toxic agents playing a keynote in the discussion is the ortho-isomer of the TCP which may cause peripheral neuropathy. Typical symptoms as after-effects of such fumes are acute breathing disorders and central neurological symptoms.

That the TCP ortho-isomer was present during the approach to Köln/Bonn on 19 December 2010 could not be proven.

A technical system recording routinely the composition and possible contamination of the cabin air in real time did not exist and was not mandatory in airplanes.

2.6.2 Differential Diagnosis

Since the BFU did not have any data available which would prove the composition of the cabin air during the approach different options for the contamination were discussed (exclusion procedure).

The BFU assessed the differential diagnostic considerations the German Airforce Institute of Aerospace Medicine had described in their expert opinion in terms of an overall view and by taking into account all known factors and marginal conditions:

- Acute exposure to carbon monoxide (CO)
- Lack of oxygen
- Contamination with insecticides
- Inhalation of de-icing fluid
- Noxa ingested with food or drink
- Cardiological disease

Acute Exposure to Carbon Monoxide (CO)

According to the expert opinion an acute exposure to carbon monoxide alone could have resulted in similar symptoms such as nausea, drowsiness, sleepiness, headaches and neurological deficits. The BFU has no knowledge of any timely determination of the blood CO level of the two pilots and therefore it could not rule out completely that such an occurrence was the trigger. Proof could no longer be established.

The examination of the technical design of the A319's cabin air system has shown that a contamination of the cockpit can be ruled out with a high degree of probability because the air in the remaining cabin did not indicate any contamination and the passengers did not exhibit any symptoms.

In regard to the possible exposure to carbon monoxide, the occurrence on 27 May 2008 after take-off in Dublin, Ireland, was also taken into consideration. The Irish investigation authority thoroughly investigated the occurrence in co-operation with the aircraft manufacturer and the operator, but causes could not be determined.

Lack of Oxygen

In principle, the scenario described in the expert opinion that lack of oxygen as sole trigger can cause symptoms such as drowsiness, weakness, feebleness and headaches cannot be ruled out completely. Here, too, possible parallels to the occurrence in Dublin, Ireland, could be drawn.

Based on the fact that the pilots breathed pure oxygen through their masks over a period of about six minutes prior to the landing a value of 80% or less which the pilots remember is not plausible.

From the medical point of view, the remaining capability to perform of both pilots does not support a value of around 80%.

Contamination with Pesticides

Contamination with pesticides, which are also used during the cleaning of airplanes, mentioned in the expert opinion is ruled out. The operator has confirmed to the BFU that an aircraft cleaning with disinfectant using pesticides did not occur in the months prior to the occurrence.

Moreover, the question would arise why the problem occurred in the cockpit only and not in the rest of the fuselage.

Inhalation of De-Icing Fluid

After the landing, employees of the operator indicated the possible smell development may be due to de-icing fluid. This theory was later communicated by the operator via a press release.

Although the problem of vaporisation of de-icing fluid remnants through the engine bleed air and distribution by the ECS sometimes happens, the BFU is of the opinion

that this scenario is highly unlikely in this case. Both pilots stated that they knew the smell and it was not present.

The BFU opinion was supported by the medical expert opinion. The expert opinion rather ruled out the possibility of the inhalation of de-icing fluid remnants addressed several times after the occurrence because this type of contamination would result in irritation of the respiratory system and headaches. Neither of the two pilots described these symptoms.

The BFU is not aware of any toxic effect which would explain the exorbitant blood levels of the co-pilot. The BFU is of the opinion, however, that de-icing fluids should be analysed in regard to possible toxic effects.

In accordance with the Safety Data Sheet for aircraft de-icing fluids corresponding to the Commission Regulations (EC) No 1907/2006 and 453/2010 the mixture should not be toxic.

Once again the question arises why the smell was noticed in the cockpit but not in the passenger cabin.

Noxa Ingested with Food or Drink

The expert opinion does mention the option of ingesting noxa with food or drink, e.g. food poisoning, but due to the lack of further data does not make an assessment. Based on the interview with the crew the BFU did not see any reason to go into more detail.

Cardiological Disease

The expert opinion did not rule out cardiological disease as reason for the symptoms but did not assess it due to missing cardiological basic data.

The BFU is of the opinion that a cardiological disease is not very likely because both pilots receive medicals on a regular basis and besides, both pilots were affected during the approach.

2.6.3 Assessment of Additional Influencing Factors

Further possible influencing factors, which were not part of the medical expert opinion, were determined by the system design of the air and climate conditioning of the airplane. These included:

- Oil leakage in one engine or the APU
- Oil leakage from the hydraulic system
- Feeding of already contaminated air from the atmosphere
- Contamination of the air by cargo or baggage
- Smell development due to malfunctioning electrical systems on board
- Leakage in the rain repellent system
- Other endogenetic influencing factors

Oil Leakage in One Engine or the APU

Oil leakage in one engine or the APU could not be ruled out. A contamination of the air in the cockpit or the passenger cabin could have occurred.

In this particular case, however, there were no indications of this type of contamination. Both pilots reported a smell which could not be brought into accord with the smell of oil. Neither were there any indications of oil vapour.

Furthermore, due to the system design of the air distribution the smell would have been noticeable in the cabin as well.

Another criterion for the exclusion was the result of the medical expert opinion. There were no reasons for the assumption of a so-called aerotoxic syndrome.

Oil Leakage from the Hydraulic System

In general, these types of dysfunctions had to be taken into consideration.

During the weekly check on 20 December 2010 overfilling of the hydraulic reservoir was determined and if additional malfunctions in the system had been present this would have resulted in hydraulic fluid entering the bleed air system. But this would have created acrid caustic smell which would have been noticed in the passenger

cabin as well due to the system design. The same is true for leakage of the hydraulic system within the pressurised fuselage.

Feeding of Already Contaminated Air from the Atmosphere

The approach path to runway 14L of Köln/Bonn Airport passed chemical plants. Therefore, it cannot be ruled out that accumulation of substances was present in the air which entered the airplane through the ECS.

On enquiry by the BFU, the Ministerium für Bauen, Wohnen, Stadtentwicklung und Verkehr of Nordrhein-Westfalen could not give any usable answer.

The BFU is of the opinion, however, that such a contamination is rather unlikely because the smell was only noticed in the cockpit and not the cabin. Due to the system design of the air distribution the smell would have been noticeable in the cabin as well.

Contamination of the Air by Cargo or Baggage

Existing air contamination can be distributed in the cabin through the ECS. Presented documentation shows that the forward cargo compartment was empty on this particular flight and therefore a contamination by cargo can be ruled out. The contents of the aft cargo compartment and the overhead bins could not be determined, therefore it cannot be ruled out completely that these could have been a source for smell. It is, however, very unlikely that, due to the air flow, smells originating from these compartments will be noticed in the cockpit but not in the cabin.

Smell Development Due to Malfunctioning Electrical Systems on Board

The determinations on the airplane and the assessment of the recorded maintenance documentation did not reveal any indications that the smell was caused by an electrical system or by a burnt electrical wire.

Such a contamination of the air in the cockpit or a local smell development due to an electrical malfunction could not entirely be ruled out. The BFU has knowledge of

cases in which e.g. a tantalum capacitor developed an intense smell. It was a temporarily extremely unpleasant smell which forced the crew to don their oxygen masks. Determination of the cause was difficult because often these tantalum capacitors only serve as buffer amplifiers in electrical gadgets. Even if a component were defective the electronic system would still be fully functional and it would be very difficult to identify the "burnt" tantalum capacitor.

Leakage in the Rain Repellent System

The BFU is of the opinion that a leakage in the rain repellent system is not very likely. Components of the system are installed in the cockpit and smell development would have been linked with leakage of the fluid. Such leakage was neither determined during maintenance nor did it occur on subsequent flights.

Furthermore, the description of the smell did not correspond with the description (pine scented) the manufacturer had given. The Safety Data Sheet classified the fluid as hazard-free. The manufacturer stated that in high concentrations irritations, indisposition and shortness of breath occur when inhaled. Both pilots confirmed that they had not noticed any irritations of their respiratory system or any acute shortness of breath.

Other Endogenetic Influencing Factors

The following endogenetic factors could have been the cause for the contamination of the cockpit and cabin air:

- Stoves in the galley
- Inappropriate or excessive use of dry ice (CO₂)
- Leakage and prohibited mixture of disinfectants in the lavatory
- Spilled lavatory fluid
- Spilled fluids
- Perspiration by animate beings

2.6.4 Physiological and Psychological Effects of Smell

The BFU concludes that there was a severe development of smell in the cockpit which was not noticeable in the cabin. The confirmation of both pilots that they had not seen any smoke or had any symptoms such as shortness of breath constitutes the conclusion: The trigger therefore was excessive smell.

During the interviews of the persons involved, the BFU never had any doubts that both pilots had shown significant physiological and psychological reactions. Even though both pilots felt significantly impaired in their capabilities to perform they could land the airplane safely.

Medical expert opinions did not show any indication of poisoning. Because the expert opinion attributed the exorbitant increase in muscular CK in the blood of one of the pilots and a muscle weakness lasting for weeks to excessive athletic sports, the BFU concluded that there was no connection to the occurrence during the approach.

It is possible that the occurrence may have resulted in significant physiological and psychological reactions described in literature⁵ and illustrated in Chapter 1.18.1. There is, however, no proof.

It is plausible to the BFU that due to severe smell development both pilots suffered physiological stress reactions such as spasms or constrictions of the peripheral blood vessels. This means the organism was activated by "alarm signals".

The BFU is of the opinion that the psychological effects were even more important. The stress situation already present during the approach was intensified by the strong, unpleasant and annoying smell. Maybe the smell was considered to be a sign of danger which may have triggered massive anxiety and fear.

Due to the known discussion about possibly contaminated cabin air in airplanes in combination with TCP and the possible consequences of neurological deficiencies, the sign of danger might even have been intensified.

This assessment refers to the determinations of this investigation. It should not be used to make generalisations in the assessment of other occurrences in combination with possibly contaminated cabin air.

Nevertheless, it is important to allude to the generally valid insight that smells can indeed have health impairment effects without being toxic.

⁵ UmweltWissen, Bayerisches Landesamt für Umwelt 2005

Ultimately, the question arises: Why were both pilots affected? A provable answer to this question cannot be given. The BFU can see only two scenarios: It has to be considered that such scenarios are possible explanations but are not proven in individual cases.

Scenario I:

The severe development of smell in the cockpit triggered reactions in both pilots. Due to his lesser professional and flying experience and the pain in his muscles caused by excessive athletic sports the co-pilot was much more affected.

The PIC also was in a situation which appeared threatening but due to his flying experience of many years he could limit the effects on him.

Scenario II:

The co-pilot was the first to have any symptoms in a generally already stressful situation during the approach.

The PIC recognised the severe effects of the symptoms the co-pilot exhibited and was psychologically so strongly burdened that he too developed symptoms.

Even though proof of the scenarios described above was not possible, the BFU has come to the conclusion that for both pilots a health hazard had developed.

2.7 Defences

2.7.1 Oxygen Masks

The investigation showed that both pilots had gotten into a serious situation including health hazard and flight safety hazard due to a strong and unpleasant smell in the cockpit.

The most important action in order to finish the approach safely, under these circumstances, was to don their oxygen masks.

In retrospect, it was very important that once the co-pilot realised the bad smell and the initial symptoms he decided to don his oxygen mask.

The same is true for the PIC who, at first, did not feel as severely affected, but then donned his oxygen mask once the initial symptoms appeared.

The investigation has made clear that it was very likely strong odour and not smoke development. In order to have a clean and odourless environment as "safe" breathable air, it was an important safety factor to don the oxygen masks. The psychological effect to have an insulated and clean environment for breathing has probably improved the situation.

2.7.2 Checklists and Training

The BFU has come to the conclusion that the checklists "SMOKE/FUMES/ANCS SMOKE" published by the aircraft manufacturer and made use of by the operator were reasonable and appropriate. Due to the situation and the time the crew did not consequently complete the checklist but trained to do so.

The routine training of smoke and smell scenarios in the flight simulator has added to the fact that the crew made timely and appropriate decisions to don their oxygen masks.

2.7.3 Safety Gate (1,000 ft)

The OM-A stipulates criteria which describe parameters for a stabilised approach. These have to be applied during the decision making process for the continuation of an approach or for aborting it.

From the vantage point of the present the decision for a go-around would not necessarily have to be made. However, it must be said that the PIC had made a conscious decision to overrule this safety mechanism before the 1,000 ft safety gate was reached.

The BFU views this decision as confirmation that the situation appeared dangerous to the crew, probably due to the health impairment.

The BFU is of the opinion that the decision to continue the approach was appropriate to the situation. Nevertheless, the Safety Gate is a significant defence mechanism.

2.8 Organisational Aspects

2.8.1 Reporting Process

The occurrence was reported to the BFU in a timely fashion. The BFU Airport Representative arrived at the airplane after about 25 minutes. By then all volatile traces in connection with possible smoke and smell development as well as the occurrences and procedures right after the landing could no longer be determined. He did, however, have the opportunity to interview the crew and other witnesses.

During interviewing of the PIC, the BFU Airport Representative did not notice the physical impairment the crew may have experienced during the approach. The interview was essentially reduced to the momentary health condition, i.e. about 20 to 30 minutes after the landing. At this time, the BFU Airport Representative did not sufficiently realise the emergency situation which had occurred prior to landing because, from his point of view, the landing had obviously run smoothly and the airplane was not parked at the emergency parking area.

Based on the PIC's estimation regarding the course of events, the BFU Airport Representative did not see the need to consult the co-pilot in the ambulance and enquire about his health condition and get his point of view regarding the course of events. Based on the experiences the BFU Airport Representative has made with so-called "Fume/Smoke Events" it was not unusual that the crew was treated in the ambulance and was taken to the hospital to have some blood tests and further diagnostics done. Had the BFU Airport Representative interviewed the co-pilot directly he might have gotten a different image regarding the course of events and the health situation.

The Air Traffic Order Para 5 reporting form the PIC had filled in had been plausible and sufficient for the BFU Airport Representative. Under the assumption the report had been sent to the BFU the BFU Airport Representative thought his duty to supply information was met.

Based on the information he had received on the evening of the occurrence, the BFU investigator on duty in Braunschweig had no reason to initiate an investigation or any other immediate actions.

The enquiry with the operator the next morning was routine. The information the operator provided that there was no smoke but smell and the crew had already been released from the hospital was a plausible decision basis to not initiate any further activities. This decision was supported by the information that the possible

contamination might have come from de-icing fluid remnants and a maintenance report would follow.

When the Air Traffic Order Para 5 reporting form arrived during the morning the investigator on duty did not have any indication that the situation had to be clarified further. Merely the question whether the oxygen masks had been donned as a precautionary action or were absolutely essential could have been addressed by the investigator on duty. The latter case would have met the decision criteria for a Serious Incident.

The Air Traffic Order Para 5 reporting form submitted by the PIC and the on-line reporting form filed by the operator contained small differences in the description of the occurrence. Whereas the report submitted by the operator talked about severe indisposition of the co-pilot and of impairment of perception of the PIC, the report filed by the PIC mentioned strong physical effects, such as nausea and dizziness, on both pilots.

For the BFU it was unusual that about one year later the severity of the occurrence came to light because of new information the BFU received. Based on an interview then conducted with the crew, the BFU had gathered facts which made it essential to initiate an investigation even one year after the occurrence. Even another interview with the crew after the Interim Report had been published was no reason for the BFU to abstain from further investigating the occurrence. Essential facts were confirmed by both pilots.

2.8.2 Flow of Confidential Information

The BFU was surprised about the distribution of the pilots' description of the event. Both pilots told the BFU that this report was meant for the operator's in-house flight safety department and the BFU only. Other departments, organisations and media should not have received this report. In regard to the facilitation of successful flight safety work and Just Culture the practised form of distribution of this report has caused considerable damage. The BFU is of the opinion that communicating an occurrence in this fashion is counter-productive because perceptions of crews are not viewed and assessed within their original context and possibly sensitive data of pilots and witnesses deserving protection are distributed uncontrolled.

3. Conclusions

3.1 Findings

- The airplane was properly certificated and maintained in accordance with existing regulations and approved procedures
- Both pilots were properly licensed and qualified for the flight.
- The class 1 medical certificates of the crew were valid.
- Prior to departure in Vienna, Austria, the airplane was de-iced.
- During the approach to Köln/Bonn Airport initially a slight and then a very strong smell developed in the cockpit.
- The smell was connected with significant symptoms of both pilots.
- Both pilots were impaired in their capability to perform.
- The pilots were forced to don their oxygen masks and to declare emergency due to the physical and psychological impairment to perform.
- Use of the oxygen masks was necessary.
- Course and glideslope for the ILS approach to runway 14L were adhered to.
- The airplane was in the required landing configuration.
- The PIC as PF conducted approach and landing manually.
- The PIC overruled the 1,000 ft safety gate before this point was reached.
- The airplane was stabilised and the flight crew had control of the airplane during the approach and the landing.
- The touch-down occurred within the stipulated distance from the threshold.
- Passengers and flight attendants did not notice any smell. They disembarked via the stairs.
- After the airplane had reached the parking position the co-pilot was supported by paramedics and helped into the ambulance. The PIC was able to leave the airplane without further assistance.
- Both pilots were treated in the ambulance and taken to a local hospital.
- Both pilots received out-patient care at the hospital.

- The co-pilot's blood parameter CK was exorbitant high. The blood gas analysis was inconspicuous.
- The PIC was fit to fly after about four days, the co-pilot after about six months.
- It is very likely that the smell originated from the inside of the airplane and did not come from the outside.

The BFU came to the conclusion that the following scenarios are unlikely:

- Malfunction of the ECS
- Oil leakage in one engine or the APU which caused contamination of the cockpit air
- Oil leakage in the hydraulic system which caused contamination of the cockpit air
- Contamination of the cockpit air due to oil vapour including release of the ortho isomer TCP
- Feeding of already contaminated air from the atmosphere
- Contamination of the air by cargo or baggage
- Contamination of the cockpit air by insecticides
- Smell development in combination with health impairment due to de-icing fluid
- Leakage in the rain repellent system
- Contamination of the cockpit by carbon monoxide
- Use of dry ice
- Noxa ingested with food or drink
- Cardiological disease

The BFU does not entirely rule out the following scenario:

- Smell development due to malfunctioning electrical or electronical systems on board

3.2 Causes

The health impairments of both pilots combined with a significant limitation of the capability to perform which had occurred during the approach were very likely caused by:

- Massive development of smell in the cockpit area whose origin and spread could not be determined.

Contributing factors could have been:

- Physiological and psychological effects of the smell on both crew members

4. Safety Recommendation

No safety recommendations were issued.

Braunschweig

25 November 2013

Investigator in charge:

Johann Reuss

Assistance:

Jens Friedemann

Klaus Himmler

Thomas Karge

Thomas Kostrzewa

5. Appendices

Appendix 1: Instrument approach chart Köln/Bonn, runway 14L, ILS

Appendix 2: Values of the meteorological balloon which ascended in Essen

Appendix 1: Instrument approach chart Köln/Bonn, runway 14L, ILS

AIP GERMANY

AD 2 EDDK 4-2-1
Effective: 17 DEC 2009

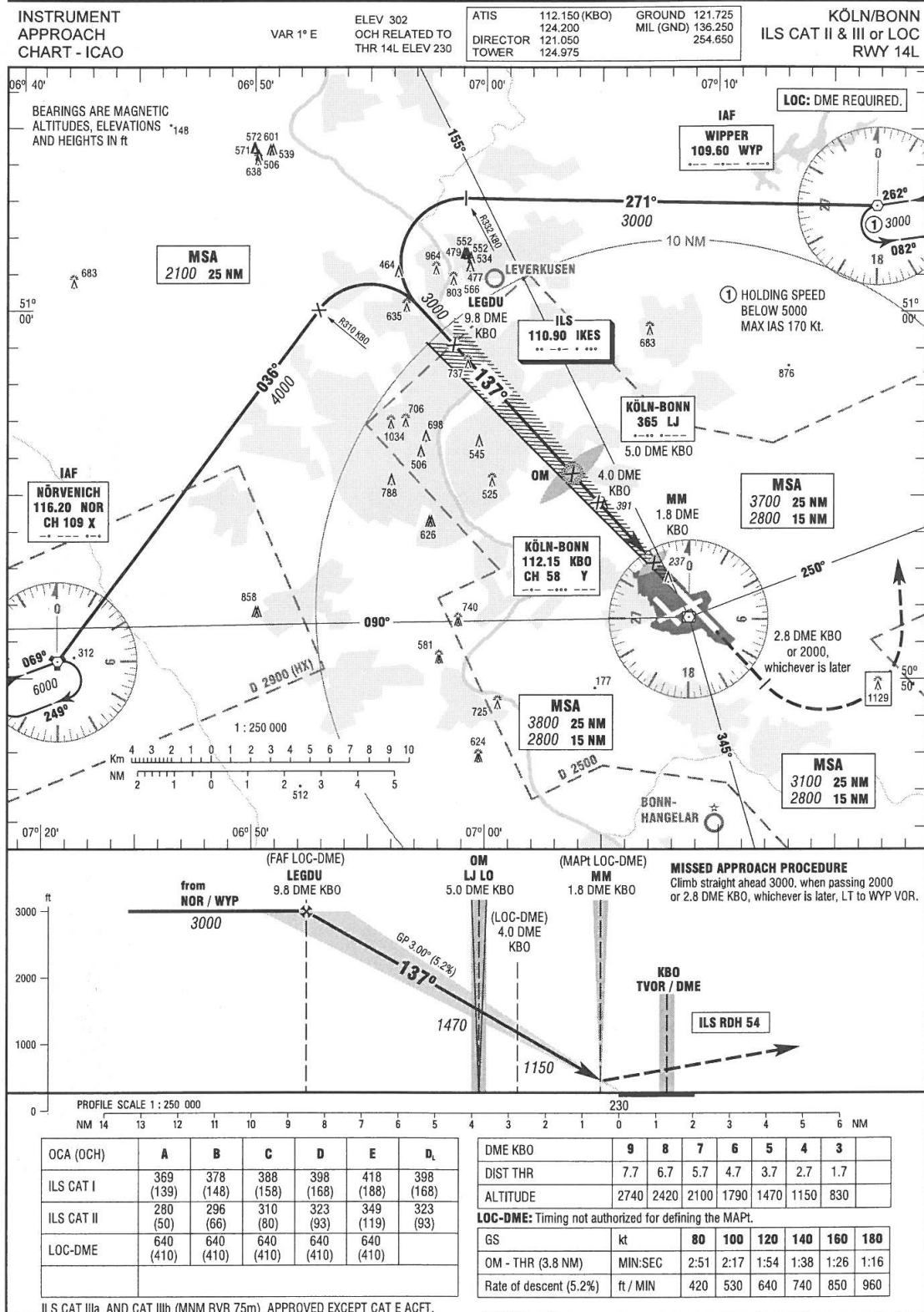

Appendix 2: Values of the meteorological balloon which ascended in Essen (U. Wyoming,

Dept. of Atmospheric Science)

10410 EDZE Essen Observations at 12Z 19 Dec 2010

PRES hPa	HGHT m	TEMP C	DWPT C	RELH %	MIXR g/kg	DRCT deg	SKNT knot	THTA K	THTE K	THTV K
1000.0	-21									
979.0	153	-1.3	-1.8	96	3.44	150	2	273.5	283.0	274.1
927.0	581	-4.7	-4.7	100	2.92	217	9	274.3	282.5	274.8
925.0	598	-4.9	-5.0	99	2.86	220	10	274.3	282.3	274.8
910.0	726	-5.8	-6.5	95	2.59	230	10	274.6	282.0	275.1
892.0	883	-6.9	-8.4	89	2.28	221	13	275.1	281.6	275.5
889.0	909	-7.0	-8.5	89	2.27	220	14	275.2	281.7	275.6
850.0	1258	-8.5	-10.0	89	2.11	230	19	277.2	283.3	277.6
848.0	1276	-8.6	-10.2	88	2.08	230	19	277.3	283.3	277.7
836.0	1387	-9.1	-11.7	81	1.88	232	16	277.9	283.4	278.2
823.0	1508	-9.4	-17.0	54	1.23	235	12	278.8	282.5	279.0
804.0	1688	-9.9	-24.9	28	0.63	255	8	280.2	282.2	280.3
798.0	1746	-9.5	-35.5	10	0.23	254	8	281.2	282.0	281.2
793.0	1795	-9.1	-34.1	11	0.27	254	9	282.1	283.0	282.2
764.0	2080	-11.0	-35.1	12	0.26	250	12	283.1	283.9	283.1
749.0	2233	-12.1	-35.6	12	0.25	265	16	283.6	284.4	283.6
734.0	2388	-13.1	-36.1	13	0.24	262	17	284.1	284.9	284.1
700.0	2747	-16.1	-42.1	9	0.14	255	19	284.6	285.1	284.6
644.0	3367	-21.9	-47.9	8	0.08	255	21	285.0	285.2	285.0
638.0	3436	-22.5	-48.5	7	0.07	255	24	285.0	285.3	285.0
617.0	3681	-23.3	-44.3	13	0.12	255	33	286.8	287.2	286.8
613.0	3729	-23.8	-40.8	19	0.18	255	35	286.8	287.4	286.8
604.0	3837	-24.9	-32.9	47	0.40	261	37	286.7	288.0	286.8
597.0	3922	-23.9	-27.7	71	0.66	265	39	288.8	291.0	288.9
581.0	4120	-24.9	-28.7	71	0.62	276	43	289.9	291.9	290.0
575.0	4195	-24.4	-28.3	70	0.65	280	45	291.4	293.5	291.5
570.0	4259	-23.9	-28.0	69	0.67	278	46	292.7	294.9	292.8
523.0	4880	-29.1	-31.0	84	0.55	263	54	293.7	295.6	293.8
501.0	5186	-31.6	-34.8	73	0.40	255	58	294.3	295.7	294.4

10410 EDZE Essen Observations at 00Z 20 Dec 2010

PRES hPa	HGHT m	TEMP C	DWPT C	RELH %	MIXR g/kg	DRCT deg	SKNT knot	THTA K	THTE K	THTV K
1000.0	-79									
972.0	153	-2.3	-2.3	100	3.34	315	6	273.1	282.3	273.6
963.0	225	-3.1	-3.2	100	3.15	345	10	272.9	281.6	273.4
953.0	306	-4.1	-4.2	99	2.95	342	11	272.8	281.0	273.3
946.0	363	-4.4	-4.5	99	2.91	340	12	273.1	281.2	273.5
927.0	520	-5.2	-5.2	100	2.81	10	14	273.8	281.7	274.3
925.0	537	-5.3	-5.3	100	2.80	10	14	273.9	281.7	274.4
921.0	571	-5.3	-5.3	100	2.81	3	14	274.2	282.1	274.7
910.0	666	-4.7	-4.7	100	2.98	343	14	275.8	284.2	276.3
900.0	752	-5.1	-5.1	100	2.92	325	14	276.2	284.5	276.7
880.0	929	-5.9	-5.9	100	2.81	320	17	277.2	285.2	277.7
864.0	1073	-6.5	-6.5	100	2.73	325	14	278.0	285.8	278.5
850.0	1201	-7.1	-7.1	100	2.65	310	8	278.7	286.3	279.1
848.0	1219	-7.2	-7.2	100	2.64	300	8	278.8	286.4	279.3
838.0	1311	-7.5	-7.7	98	2.57	290	10	279.4	286.8	279.8
825.0	1433	-8.0	-8.4	97	2.47	290	12	280.2	287.4	280.6
786.0	1809	-9.3	-10.5	92	2.20	255	23	282.6	289.1	283.0
771.0	1958	-9.9	-11.3	89	2.10	258	26	283.6	289.8	283.9
762.0	2048	-10.4	-11.9	89	2.02	260	27	284.0	290.0	284.3
741.0	2262	-11.6	-13.3	87	1.85	270	27	284.9	290.5	285.2
700.0	2698	-14.1	-16.3	83	1.54	265	29	286.8	291.6	287.1
679.0	2928	-15.3	-17.3	85	1.46	260	35	288.0	292.5	288.2
640.0	3374	-17.7	-19.2	88	1.32	246	44	290.2	294.3	290.4
638.0	3397	-17.9	-19.4	88	1.30	245	45	290.2	294.3	290.5
596.0	3895	-21.8	-23.4	86	0.97	245	51	291.4	294.5	291.6
527.0	4796	-28.9	-30.8	84	0.56	245	44	293.3	295.2	293.4
510.0	5029	-31.0	-33.0	83	0.47	245	43	293.5	295.1	293.6
500.0	5170	-32.3	-34.3	82	0.42	245	45	293.6	295.0	293.7