

# Investigation Report

## Identification

Type of Occurrence:	Serious incident
Date:	8 October 2014
Location:	Frankfurt/Main
Aircraft:	Cargo airplane
Manufacturer / Model:	The Boeing Company / B 747-400 F
Injuries to Persons:	None
Damage:	Minor damage to aircraft
Other Damage:	None
State File Number:	BFU EX007-14

## Factual Information

During the approach to Frankfurt/Main Airport parts of the left wing flap detached from the airplane.

## History of the Flight

At 1427 hrs<sup>1</sup> the freighter was on final approach to Frankfurt/Main Airport. It was on a flight from Moscow, Russia. Four persons were on board: two pilots, flying the air-

---

<sup>1</sup> All times local, unless otherwise stated.

plane, one substitute pilot seated in the jump seat at the rear of the cockpit, and one other substitute pilot.

The Pilot in Command (PIC) in the left-hand seat was Pilot Flying (PF). The approach to runway 25L was conducted with engaged autopilot.

The crew stated that at approximately 2,500 ft AMSL as the flaps extended from 20° to 30° they heard a sound similar to the landing gear extending. Immediately afterwards the airplane rolled left about its longitudinal axis by approximately 7°. At that time the Indicated Air Speed (IAS) was 160 kt. Then the autopilot was disengaged and the PIC steered the airplane manually back to the Instrument Landing System (ILS) approach path.

The landing occurred without further problems. The airplane taxied to the parking position. There the missing part of the left wing inboard fore flap was noticed.

## Personnel Information

The 64-year-old PIC held an Airline Transport Pilot's License (ATPL) with the commensurate Boeing B 747-400 type rating issued by the South-Korean aeronautical authority. He held a valid class 1 medical certificate. According to the airline he had a total flying experience of 18,009 hours; 13,671 hours of which on Boeing 747-400.

The 32-year-old co-pilot held a Commercial Pilot's License (CPL) with the commensurate Boeing B 747-400 type rating issued by the South-Korean aeronautical authority. He held a valid class 1 medical certificate. According to the airline he had a total flying experience of 2,236 hours; of which 548 hours were on Boeing 747-400.

The second co-pilot, age 40, held a Commercial Pilot's License (CPL) with the commensurate Boeing B 747-400 type rating issued by the South-Korean aeronautical authority. He held a valid class 1 medical certificate. According to the airline he had a total flying experience of 4,940 hours; of which 3,549 hours were on Boeing 747-400.

## Aircraft Information

The B747-400 F manufactured by The Boeing Company is an all-metal, low-wing aircraft with retractable tricycle nose wheel landing gear. The airplane was powered by four Pratt & Whitney PW4056 jet engines. According to the flight manual, maximum take-off mass was 394,625 kg and maximum landing mass 295,742 kg. The calculated landing mass entered in the loading sheet for the landing in Frankfurt was

255,652 kg. The aircraft with the manufacturer's serial number 26414 was built in 2002. According to the Flight and Maintenance Log total operating time of the aircraft was 59,155 hours and 10,506 cycles.

The aircraft was registered in the Republic of Korea and operated by a South-Korean operator.

The fractured flap attach fitting was of the aluminium alloy EN AW 7075. On one side it had been screwed to the flap spar (Appendices Image 6). The bearing seat in form of a ball joint was located at the other end. A steel ball, through which a retaining bolt was guided, was resting in a bronze bushing (Image 6a). During assembly the bronze bushing was pushed up to the lap into the eye of the attach fitting. The side without lap was flared so that the bushing remained firmly in the eye and could not be pressed out. A circumferential groove ran along the outside of the bushing which was connected with the inside of the bushing via three drill holes. Via the groove and the drill holes the ball was supplied with lubrication. A fitting on the outside connected with the inside via a drill in the area of the groove guided the lubricant inside.

A bolt, which led through the drill hole to the ball, connected the attach fitting with the carriage, which moved the flap (Image 6a).

## Meteorological Information

The aviation routine weather report (METAR) at Frankfurt/Main Airport of 0720 UTC described the weather conditions as follows:

Wind:	100°/04 kt
Visibility:	More than 10 km
Clouds:	1 to 2 oktas at 1,500 ft; 5 to 7 oktas at 17,000 ft
Temperature:	12°C
Dewpoint:	12°C
Barometric air pressure (QNH):	1,010 hPa

## Aids to Navigation

The instrument approach procedure was conducted with the Instrument Landing System (ILS) of runway 25L.

The air traffic control service provider provided the BFU with the radar recording of the approach.

## Radio Communications

During the approach and landing the crew was in radio contact with approach control and Frankfurt Tower. Radio transmissions were recorded. The transcripts were made available to the BFU for evaluation purposes. There was no usable information regarding the fracture of the flap.

## Aerodrome Information

Frankfurt/Main Airport has two asphalt runways. The runways 07R/25L and 07C/25C are each 4,000 m long and 45 m and 60 m wide, respectively. A third runway 07L/25R is 2,800 m long and 45 m wide. It has a concrete surface. Runway 18 also has a concrete surface and is 4,000 m long and 45 m wide.

## Flight Recorder

The Flight Data Recorder (FDR), Honeywell SSFDR-11224, and the Cockpit Voice Recorder (CVR), Fairchild Model A200S, were available to the BFU for read-out. The FDR recordings showed that after the flaps had been fully extended the airplane rolled left by 7°. Afterwards the autopilot was disengaged and the flight attitude corrected manually. The continuing flight and the landing occurred without further incident.

## Findings at the Aircraft

On the airplane part of the left wing inboard fore flap (approximately 4.5 x 1 m) was missing. The fracture had occurred approximately one metre left of the inner flap attach fitting (Images 1 - 3). The two outer fore-flap tracks, connecting the fore and middle inboard flap, were fractured or damaged. The cover panels of the fore-flap track's mountings showed damages. In the area of the carriage, which moves the outer bearing of the flap, a fracture piece of the bearing seat got jammed (Image 8). The bronze bushing was still connected with the carriage through the bolt (Image 9). Image 5 shows a drawing of the flap arrangement and the fractured attach fitting. The

left outer inboard fore flap attach fitting (Image 7) with the Part Number ASSY 65B39025-29 /-31 had fractured.

The severed flap part was found in a forest close to Frankfurt/Main and transported to the BFU for further examination (Image 4).

Putting all three pieces back together revealed that they fit perfectly. The examination of the fracture surfaces of the flap attach fitting showed that the fracture surface on the flap part found on the ground was heavily deformed. Therefore, this fracture piece could not be used for further analysis. The counter fractures were located on the bearing seat piece, which had become jammed in the carriage area. The Institut für Füge- und Schweißtechnik der Technischen Universität Braunschweig (ifs) examined them in their laboratory.

During macroscopic examination clear characteristics of fatigue fracture were visible (Image 10). These lines of rest indicated fracture propagation from inside to outside (Image 11). The examination with the scanning electron microscope (REM), Jeol JSM-6480, showed clear striations (Images 12 and 14) and confirmed the fatigue crack. The crack origins on the inside of the fracture piece showed holes and depressions which indicated corrosion (Image 13). Further examination of the drill hole surface clearly showed corroded areas. It was noted that the area of the lubrication groove showed significantly less corrosion (Image 16) than the larger area of the drill hole surface. They looked like holes or depressions. Another crack was found there (Image 16). The fatigue cracks, which ultimately resulted in the fracture of the component, originated in just such an area. The residual fracture showed a ductile fracture structure (Image 15).

The metallographic cross specimen showed clearly strong corrosion on the entire inside of the fracture part. The base metal seemed to dissolve. It was also clearly visible that the areas outside the lubrication groove were significantly more affected. The metallographic examination also revealed that the groove of the drill hole surface had a different mechanical quality (Image 17).

The result of the chemical analysis confirmed the material data of the manufacturer. The cupreous aluminium alloy EN AW 7075 had been used, which is well-established in aircraft design.

## Additional Information

### Past Occurrences

In the history of the aircraft type damages to and loss of flaps or parts of flaps occurred at times. These were caused by inaccuracies in the adjustment of the runner system with which the flaps were moved and guided. Insufficient lubrication of the runner system also resulted in damages.

There were cases where corrosion was the trigger for the fracture of the attach fitting and subsequent loss of flap parts. Such an event occurred on 8 May 2009 during the approach to Frankfurt/Main Airport which the BFU also investigated (File Number: AX001-09). The course of events was almost identical. However, the fractured flap parts had punctured the fuselage and damaged the tail section.

The fracture pieces found from the past events also showed fatigue fractures which resulted in the failure of the flap attach fitting. Up until now the fracture origin could not be determined, because in the past the surface of the fracture origin had been damaged. In this case the fracture face was preserved and therefore the entire fracture propagation could be determined.

With the experiences from this case, the case from 2009 (AX001-09) was re-examined.

### Actions by the Manufacturer

On 20 June 1975 the manufacturer, as type certificate holder, issued the Service Bulletin Revision 2 (SB) 747-57-2119 (Image 18). The reason for publishing the SB was a fatigue crack on the outer attach fitting of the inboard fore flap, which had occurred on a test airplane for dynamic fatigue tests after 12,000 simulated flights. The SB reports of other cases reported by aircraft operators where flap attach fittings had cracked or fractured. The SB describes the replacement of the old with improved and reinforced attach fittings.

On 14 November 2003 the manufacturer issued the Service Letter 747-SL-57-097 (Image 19). It describes the fracture of an inboard flap attach fitting due to corrosion. As a result the corrosion resistance of the component was enhanced. According to the aircraft manufacturer a different material (7075-T351 instead of 2024-T351) was used. Both are well-established aluminium alloys in aircraft design. It was recommended that the aircraft operators should replace the installed flap attach fittings with improved ones.

## Analysis

According to the crew's statement, which was confirmed by the FDR recording, the fracture of the flap occurred during approach to Frankfurt/Main Airport shortly after the flaps had been fully extended.

The fracture of the attach fitting was due to fatigue corrosion. The corrosion, in consequence of the used material, resulted in kerfs which, in correlation with stress, served as crack origin for fatigue fracture. The fatigue fracture propagated until the remaining section was destroyed by ductile forced rupture. Because of a well-preserved fracture surface of the attach fitting the fracture origin and the fracture propagation could be established conclusively. Trigger for the fracture of the remaining section was the extension of the flap and the corresponding stress increase, which the section could no longer tolerate.

The corrosive damage is not uncharacteristic for the used material. Literature referring to corrosion characteristics of aluminium alloys, such as the cupreous EN AW 7075, describes the corrosion susceptibility due to their copper content.

The area of the lubrication groove of the bronze bushing showed a different surface condition which was clearly less susceptible to corrosion.

Due to the fracture of the attach fitting the flap lost its outer mounting. Subsequently, it flapped upward and fractured.

This resulted in additional damages in the periphery of the flap. The airplane itself was not hit or damaged by severed components. The FDR recordings showed that the loss of a flap part did not have any significant influence on the flight characteristics of the airplane. The PIC was able to manually counteract the loss of lift capacity during approach. The landing occurred without further problems.

There is an increased risk for third parties, because an airplane is usually in final approach to an airport and therefore often above metropolitan areas, when the flaps are extended. That in the past as well as in this case no persons or objects suffered injuries or damages is a stroke of luck. The BFU is of the opinion that there exists general need for action to improve the flap attach fitting for this aircraft type.

In November 2003 the manufacturer issued the Service Letter 747-SL-57-097, which describes the fracture of the inner attach fitting of the inboard fore flap. The described facts are also true for the outer attach fitting of this particular case. According to the manufacturer the improvement consisted of the change of aluminium alloy to the ma-

terial 7075-T351. This alloy is already used for the outer attach fitting, as the present case shows. It is therefore possible that enhancement of corrosion resistance could be achieved by surface treatment. The investigation revealed that the area of the lubrication groove on the surface of the attach fitting was less corrosion susceptible. The BFU views this as a possible future solution method to improve corrosion protection.

The SB 747-57-2119 Revision 2 issued in June 1975 covered damaged and fractured outer attach fittings of inboard fore flaps. Back then different causes had been identified. There was no explicit description of damages and fractures caused by corrosion.

## Conclusions

The flap attach fitting was destroyed by an extended fatigue fracture. It is highly likely that it started with a corrosion depression.

## Safety Recommendations

Safety Recommendation No. 05/2018

The aircraft operator should check the flap attach fittings used in their Boeing B 747-400 aircraft pursuant to the revised manufacturer's Service Bulletin (SB) 747-27-2366R3 and the Service Letter 747-SL57085-C and, if appropriate, replace them.

Safety Recommendation No. 06/2018

The aircraft manufacturer, as type certificate holder of aircraft type Boeing B 747-400, should enhance the corrosion resistance of the flap attach fitting, especially in the bearing seat area.

Investigator in charge:	Nehmsch
Field investigation:	Jäkel, Nehmsch
Assistance:	Jäkel, Ritschel

Braunschweig 29/03/2018

## Appendices



Image 1: The fractured flap viewed from below

Source: BFU

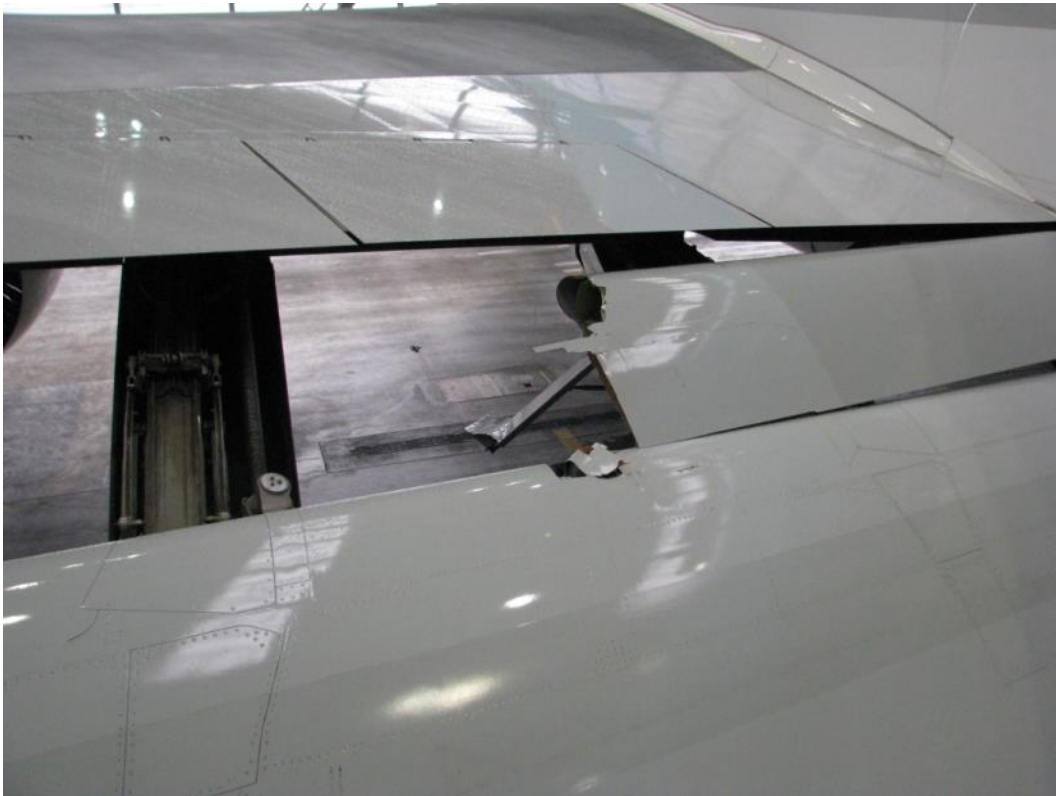

Image 2: The fractured flap viewed from above

Source: BFU



Image 3: Outer mounting point of the flap

Source: BFU



Image 4: Fractured flap part

Source: BFU

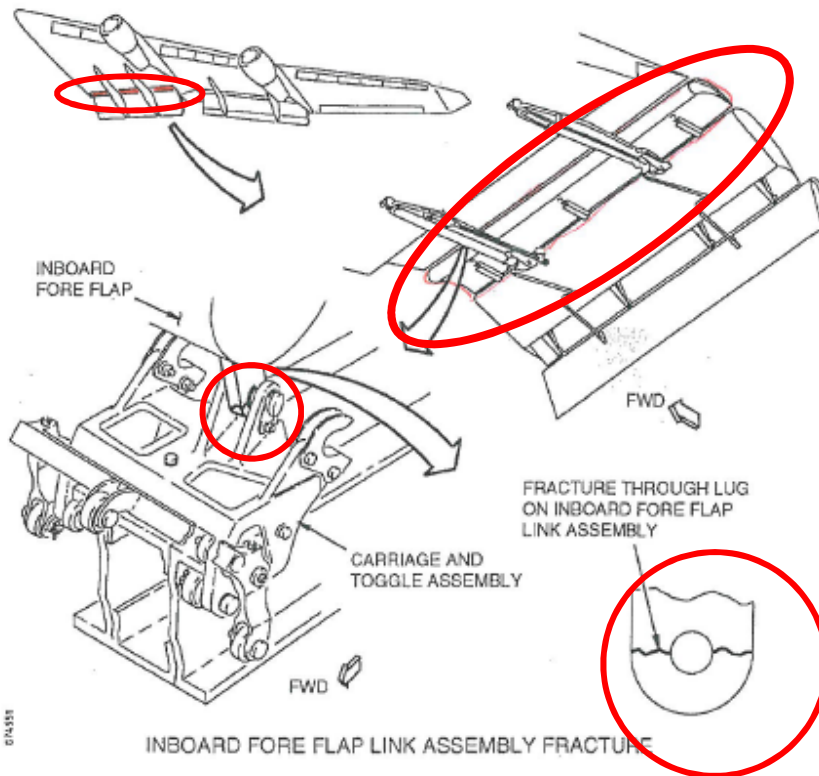

Image 5: Assembly and position of the inboard fore flap with fracture on the attach fitting

Source: Manufacturer

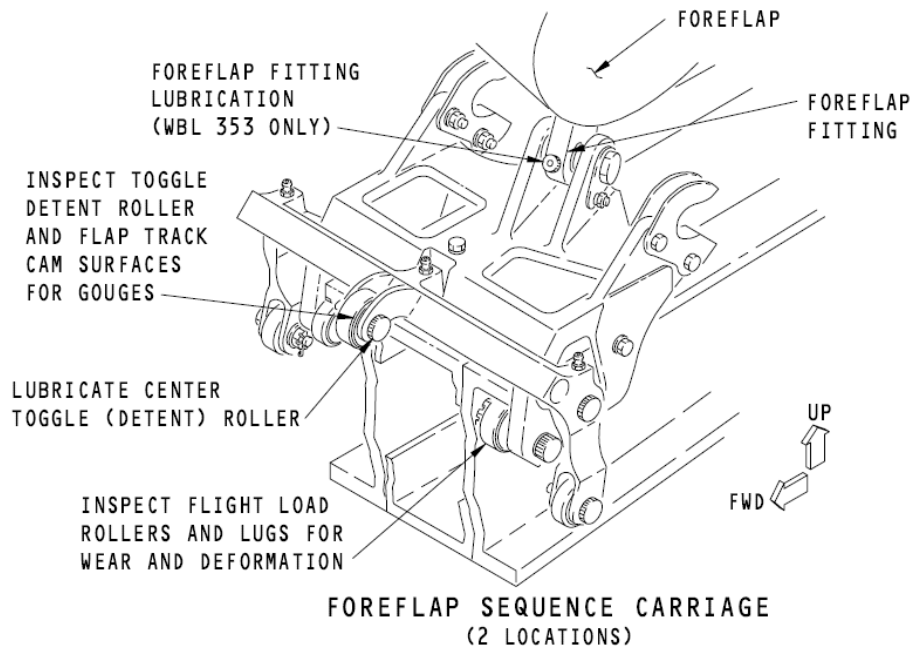

Image 6: Link between inboard fore flap and carriage

Source: Manufacturer

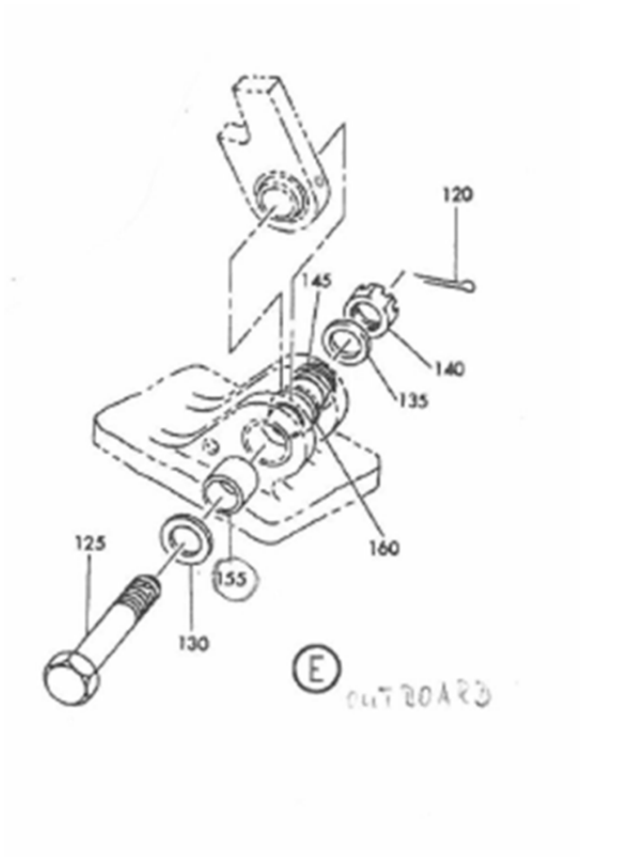

Image 6a: Detail link between inboard fore flap and carriage

Source: Manufacturer

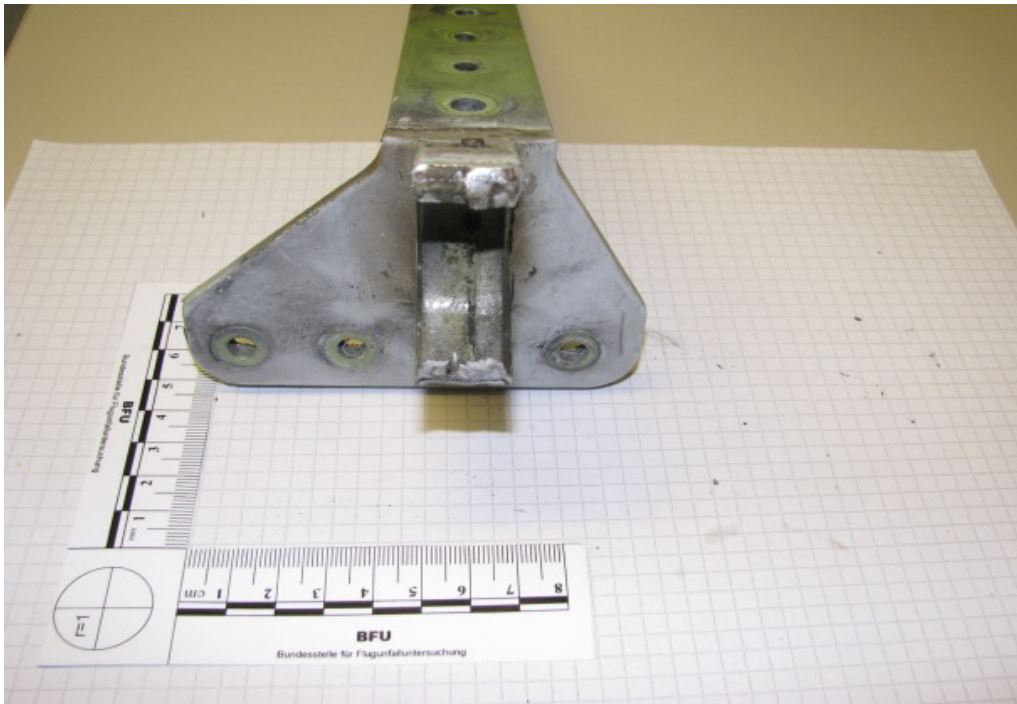

Image 7: Flap attach fitting with lower bearing seat, fracture surfaces severely damaged

Source: BFU

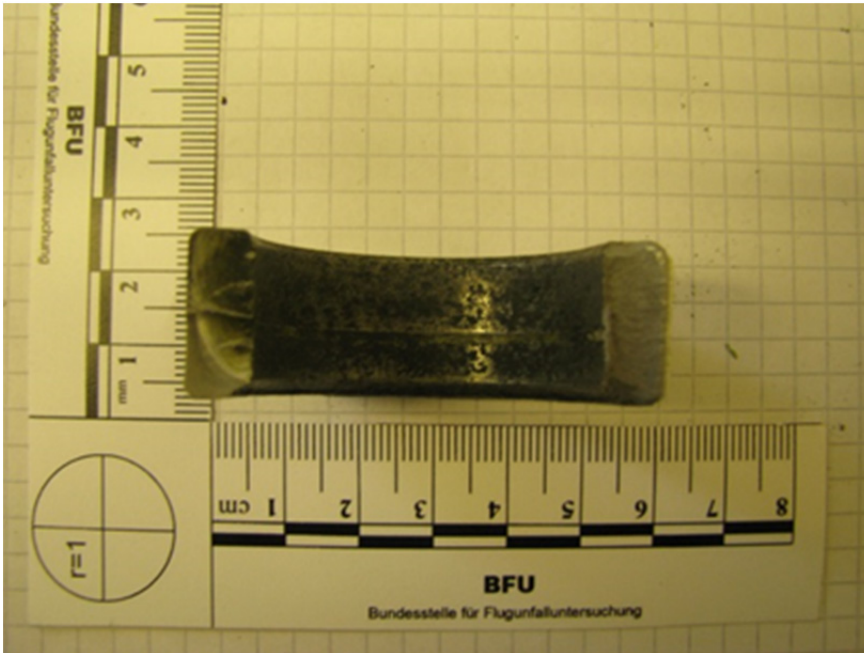

Image 8: Upper part of the bearing seat with well-preserved fracture surfaces Source: BFU



Image 9: Pin with bronze socket at the carriage

Source: BFU

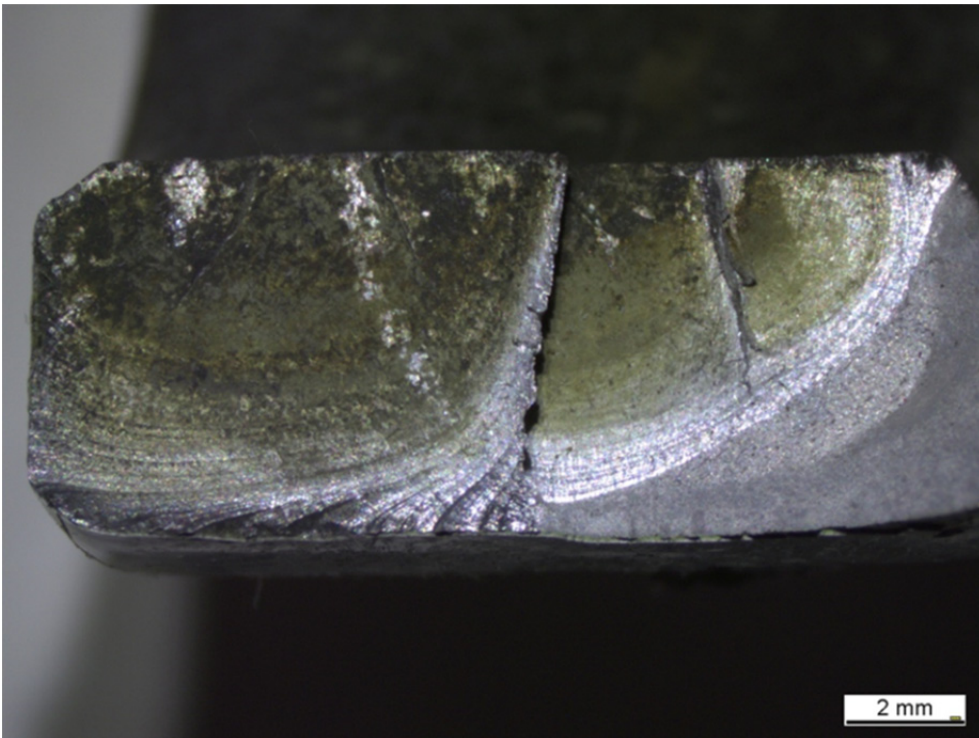

Image 10: Fracture surface on the upper bearing seat (at delivery)

Source: ifs

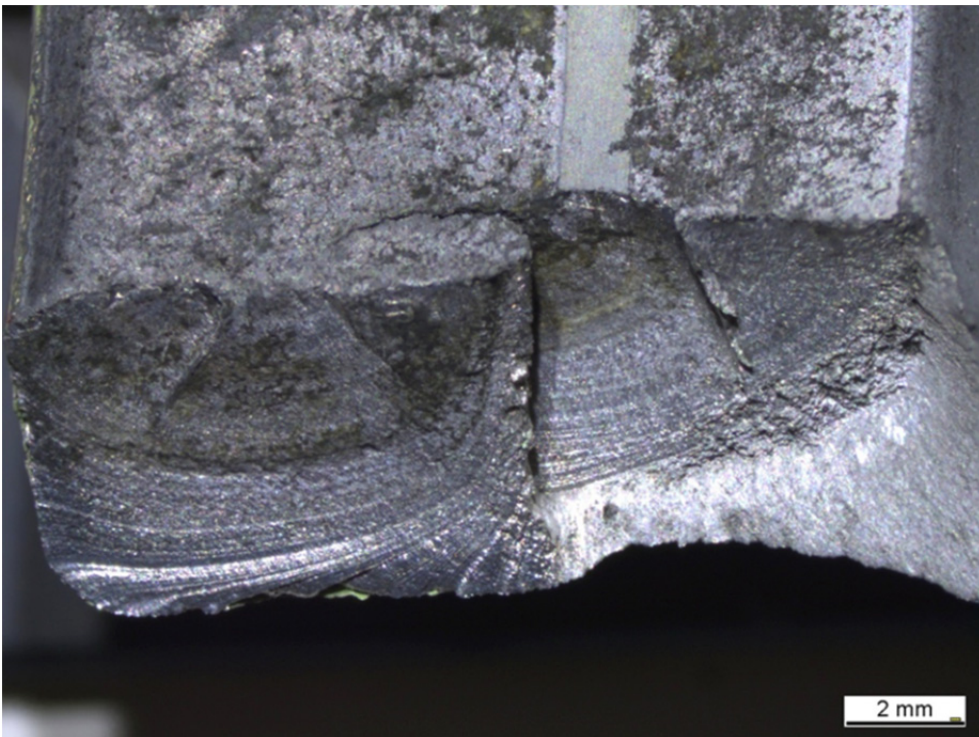

Image 11: Fracture surface on the upper bearing seat (cleaned)

Source: ifs

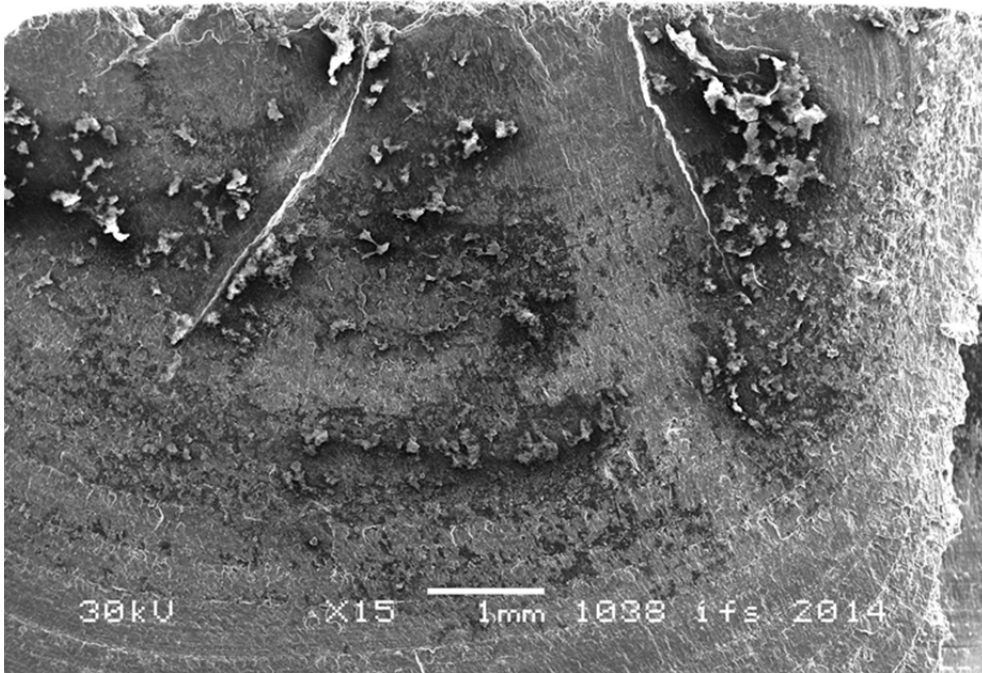

Image 12: Fracture origin

Source: ifs



Image 13: Fracture origin with corrosion

Source: ifs

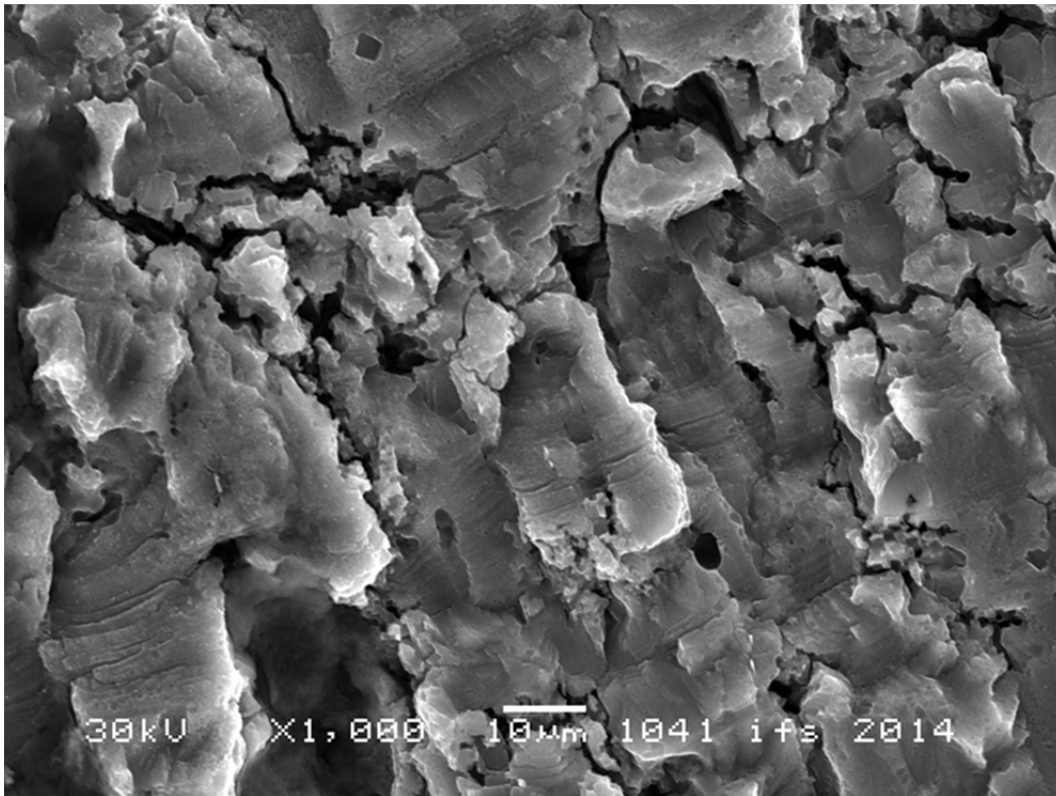

Image 14: Detail enlargement of the fracture surface with striations

Source: ifs

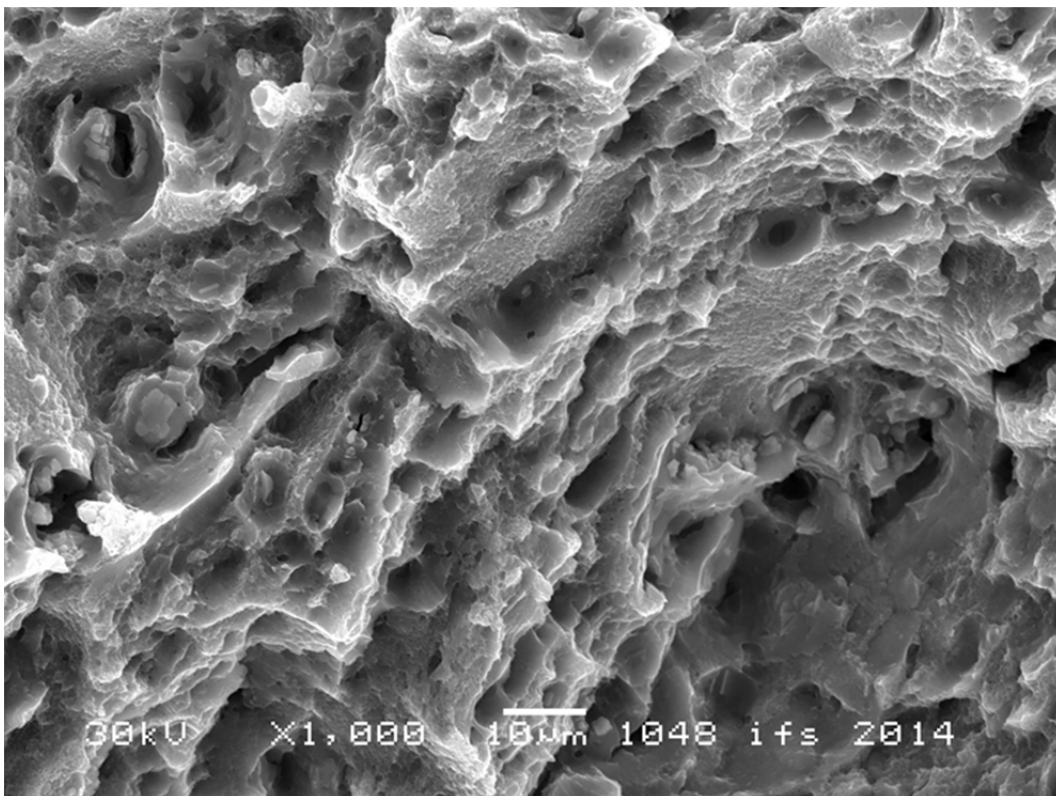

Image 15: Detail enlargement of the residual fracture, ductile forced rupture

Source: ifs

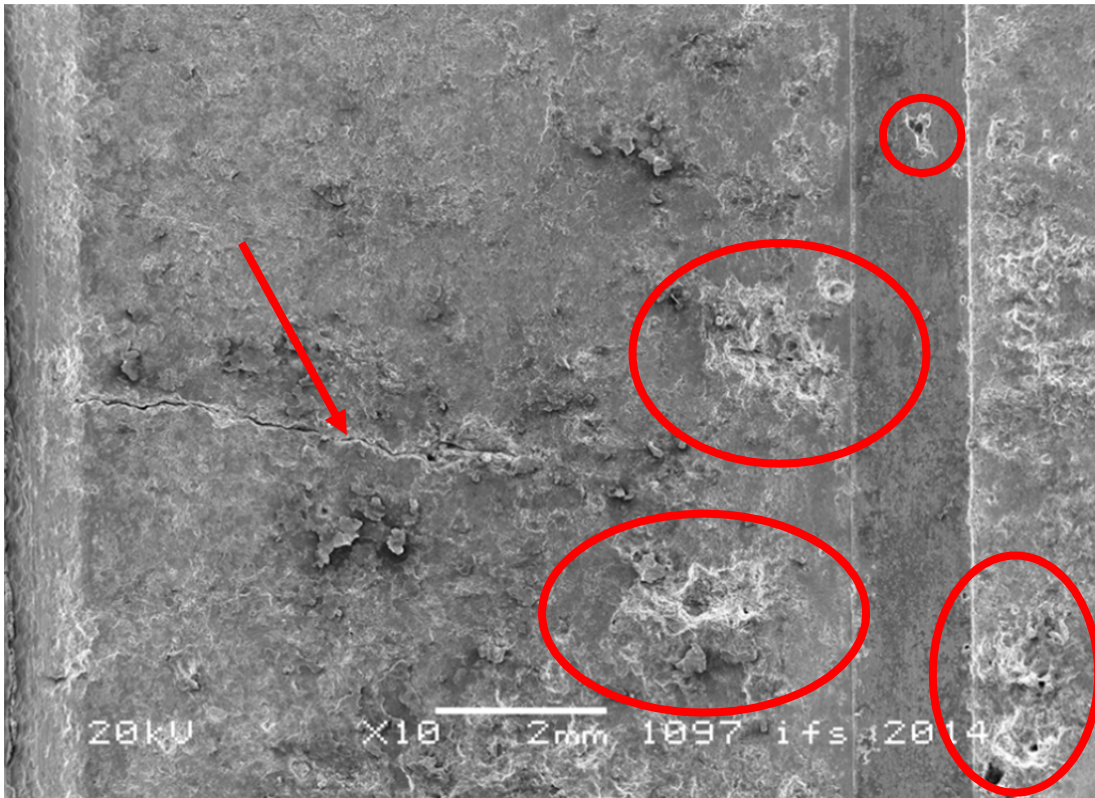

Image 16: Surface structure of the inside of the bearing seat, corrosive area (encircled) another crack (arrow), lubrication groove (right)

Source: ifs



Image 17: Metallographic overview of the heavily corroded inside with lubrication groove (arrow)

Source: ifs

## Image 18: Excerpt Service Bulletin SB 747-57-2119-02:

REVISION  
TRANSMITTAL SHEET

Boeing Service Bulletin 747-57-2119

747

This sheet transmits REVISION 2 dated June 20, 1975 to Service Bulletin 747-57-2119, "Inboard Trailing Edge Fore Flap Outboard Sequence Carriage Attach Fitting Replacement."

NOTE: This revision constitutes a complete reissue.

SUMMARY

Revision 1 of this bulletin requested a one-time inspection, with results reported to Boeing, and noted that repeat inspection requirements, if any, would be determined based on initial inspection results. Based on recent service experience and initial inspections, this revision is issued to specify a continuing inspection program on uncracked fittings until fittings are replaced with improved fittings. Please notify Boeing of planned action through the Boeing Customer Support Representative.

In addition, based on recent service experience, this revision emphasizes the benefit to be gained by early incorporation of this modification, as the new fittings provide considerably more strength to resist abnormal loading that can develop if the fore flap track rollers located in the mid flap are corroded or seized.

Also, during modification of an airplane at Boeing, it was found that the oversize bolts used to attach the fitting horizontal flange to the fore flap lower surface could not be installed in the nutplates because of interference with the bolt shank. Therefore, instructions are added in this revision to use nuts and washers rather than nutplates and new kits are defined. In addition, the Parts Accountability Table is revised to reflect the correct superseding part number, the effectivity is updated to reflect latest airplane ownership, and minor editorial changes are incorporated.

Airplanes modified per the previous releases of this bulletin may require additional rework if nutplates were installed on the fore flap for attachment of the fitting horizontal flange, and interference was encountered with the oversize fasteners. If this condition exists, the nutplates should be replaced with nuts and washers.

Summary and pages 1-8, 11-43 of this revision contain new or revised information.

REVISION HISTORY

Original Issue:	May 31, 1974
Revision 1:	September 24, 1974
Revision 2:	June 20, 1975

THE BOEING COMMERCIAL  
AIRPLANE COMPANY  
CUSTOMER SUPPORT



# BOEING 747

THE BOEING COMMERCIAL AIRPLANE COMPANY

P.O. BOX 3707 SEATTLE, WASHINGTON 98124

**SUBJECT:**  
 INBOARD TRAILING EDGE FORE FLAP  
 OUTBOARD SEQUENCE CARRIAGE ATTACH  
 FITTING REPLACEMENT

## SERVICE BULLETIN SUMMARY

NO: 747-57-2119 DATE: May 31/74  
 REVISION 2: June 20, 19

PLEASE NOTIFY BOEING  
 REPRESENTATIVE OF  
 PLANNED ACTION

### MATERIAL INFORMATION

Kit	Price
63B12156-10	\$984.00

### BACKGROUND

A fatigue crack was found in the horizontal flange of the inboard fore flap outboard attach fitting on the fatigue test airplane after 12,000 simulated flights. Subsequently, three in-service cracks were reported at 2300 to 3500 flights. Undetected cracking could result in complete fracture of the fitting and loss of the fore flap in flight. Subsequent to Revision 1, three fore flap losses have been reported. The most recent loss, at 5508 flights, resulted in considerable damage to No. 4 door.

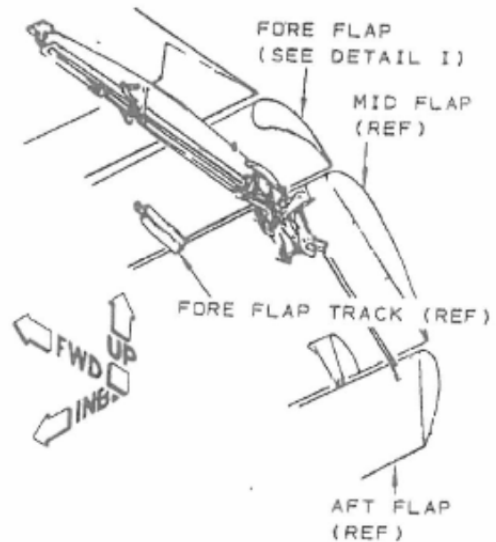

VIEW LOCKING UP AT INBOARD TRAILING EDGE FLAPS

### ACTION (PRR 75602)

Inspect outboard sequence fitting for cracks on airplanes with over 2000 flights. Repeat inspection every 200-300 flights until the existing inboard fore flap outboard attach fitting is replaced with an improved fitting with thicker flanges.

### EFFECTIVITY

Group I: Cum. Line - 001 thru 087  
 Group II: Cum. Line - 088 thru 151  
 Group III: Cum. Line - 152 thru 226

### MANPOWER

Total Man-Hours - 50 (Mod.), 8 (Inspect)

Airplane Down-Time - 10.5 (Mod.), 2 (Inspect) Hours

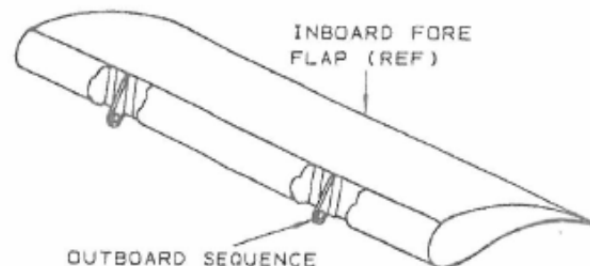

OUTBOARD SEQUENCE FITTING (REPLACE)

DETAIL I

Summary Page 1 of 1

# BOEING

THE BOEING COMMERCIAL AIRPLANE COMPANY P.O. BOX 3707 SEATTLE, WASHINGTON 98124

## SERVICE BULLETIN

 ATA  
 SYSTEM: 5750

 NO: 747-57-2119  
 DATE: May 31, 1974  
 REVISION 2: June 20, 1975

**SUBJECT:** INBOARD TRAILING EDGE FORE FLAP OUTBOARD SEQUENCE  
 CARRIAGE ATTACH FITTING REPLACEMENT

### I. Planning Information

#### A. Effectivity

##### 1. Airplanes Affected

An equivalent change will be incorporated on applicable airplanes in production per PRR 75602. This service bulletin applies to 747 production cumulative line number 001 thru 226 in 3 groups as follows: Group I, cum. line 001 thru 087; Group II, cum. line 088 thru 151; Group III, cum. line 152 thru 226. Customer identification of applicable airplanes is listed below.

**NOTE:** Effectivity is divided into three groups to reflect differences in rework requirements.

CUSTOMER & CUSTOMER NO.	MODEL & SERIES	REG. SERIAL NO.	REGISTRY NO.
<b>GROUP I</b>			
AA (AMERICAN) RA903-RA907 RA909	747-123	20102 THRU 20106	N0663 THRU N0667
	747-123	20108	N0669
AF (AIR FRANCE) RA251-RA254	747-128	10740 THRU 10750	F-BPMD THRU F-BPMD
AR (ARGENTINAS) R.631	747-132	10006	*

\* Registry number not available.

 May 31/74  
 REV. 2: Jun 20/75

 747-57-2119  
 Page 1 of 43

## BOEING SERVICE BULLETIN NO. 747-57-2119

B. Reason

This modification will reduce the possibility of fatigue cracking in the outboard attach (sequence) fitting for the inboard trailing edge fore flap.

The inboard trailing edge fore flaps are connected by two attach fittings to sequence carriages which move along each inboard flap track to establish the fore flap position. The fore flap is also supported by three tracks which extend into the mid flap on rollers.

A fatigue crack was found in the fillet radius between the lug and the horizontal flange of the fore flap outboard attach fitting on the fatigue test airplane after accumulation of 12,000 simulated flights. An undetected fatigue crack in a fore flap attach fitting could eventually result in complete fracture of the attach fitting. Complete fracture of the fore flap attach fitting would leave the outboard end of the fore flap unrestrained and partial or total loss of the fore flap could occur in flight, possibly causing damage to other airplane structure.

Subsequent to the original issue of this bulletin, three instances of cracking of the horizontal flange have been reported by two operators at 3482, 2900, and 2299 flights. All three cracks originated in a different location than the fatigue test crack. They were all found at the outboardmost fastener hole in the horizontal flange, and they propagated in an inboard-aft as well as outboard direction.

The cracks were caused by cyclic loading and are believed to be aggravated by a fit up problem which increased the stress level in the horizontal flange. Because of the direction of the operating side load, the highest stress level is expected to occur at the outboardmost fastener hole. The one-time inspection requested by Revision 1 of this bulletin resulted in 11 additional reports of cracks of this type.

## BOEING SERVICE BULLETIN NO. 747-57-2119

Subsequent to Revision 1 of this bulletin, three instances of loss of the inboard fore flap have been reported by two operators. These losses have been attributed to cracking and subsequent breakage of the outboard attach fitting. In two of these instances, the failures were caused by higher than normal loads imposed on the fittings by corroded and seized fore flap track rollers, possibly aggravated by incorrect shimming of the fitting horizontal flanges. In the other instance, incorrect shimming of the horizontal flange of the fitting is believed to have been the major contributing factor in fitting failure.

The most recent instance of fore flap loss, which occurred at 5508 flights, resulted in damage to the body skin below passenger floor level and considerable damage to the No. 4 door due to impact by the departing fore flap.

C. Description

To reduce the possibility of fatigue cracks occurring in the inboard fore flap outboard attach fitting, the existing outboard fitting may be replaced with an improved fitting having increased fatigue life. The new fitting has a thicker flange where it is attached to the fore flap front spar vertical web. A doubler is required between the horizontal flange of the new fitting and the fore flap lower skin to provide proper fitting alignment in the vertical direction. The fitting also has a thicker horizontal flange.

The new outboard attach fitting will also provide additional strength to resist loads imposed on the fore flap if the rollers in the mid-flap become seized.

The effectivity has been divided into three groups to facilitate referencing to configurational differences. Group I airplanes were delivered with the "A" flap system and Group II and III airplanes were delivered with the "B" flap system. Conversion to the "B" flap system per Service Bulletin 27-2060, "Aft Trailing Edge Flap Track Fairing Actuator System Conversion" does not affect airplane rework.

NOTE: It is suggested that this service bulletin be accomplished concurrently with Service Bulletin 57-2088, "Wing Trailing Edge Inboard Foreflap Sequencing Fitting Replacement" on Group I and II airplanes to take advantage of common access requirements. Group III airplanes received the intent of Service Bulletin 57-2088 in production.

May 31/74  
REV. 2: Jun 20/75

747-57-2119  
12

## BOEING SERVICE BULLETIN NO. 747-57-2119

Based on recent service experience and results of previous inspections, it is recommended that the fitting horizontal flange at the fastener holes and in the fillet radius of the flange-to-bearing lug be penetrant or eddy current inspected for cracks on all affected airplanes with 2000 or more flights. Fastener removal is not required. Repeat inspections should be accomplished at regular maintenance intervals not to exceed 300 flights, until fitting replacement is accomplished. If cracked fittings were replaced with like fittings, rather than the new improved fittings, inspection of these fittings should commence after accumulation of 2000 flights.

Installation of the new fittings requires shim check and adjustment as required, and the new fittings provide considerably more strength to resist corroded or seized flap track rollers. Therefore, because of the potential for loss of inboard fore flaps, operators are encouraged to consider early incorporation of this modification.

Please notify Boeing of inspection plans and modification schedules through the Boeing Customer Support Representative.

NOTE: Reference to this bulletin is contained in Notice of Proposed Rule Making Docket No. 75-NW-16-AD dated June 2, 1975.

D. Approval

The replacement described herein has been approved by the FAA Designated Engineering Representative at the Boeing Commercial Airplane Company and coordinated with FAA Northwest Region.

Image 19: Service Letter 747-SL-57-097:



Commercial  
Aviation  
Services

# SERVICE LETTER

SERVICE ENGINEERING • BOEING COMMERCIAL AIRPLANES • P.O. BOX 3707 • SEATTLE • WASHINGTON 98124-2207

747-SL-57-097  
ATA: 5755-10  
14 November 2003

**SUBJECT:** INBOARD FORE FLAP LINK ASSEMBLY IMPROVEMENT

**MODEL:** 747 Series

**APPLICABILITY:** All 747 Model Airplanes prior to Line Position 1335, except –SP Model (Line Position 1335 delivered in October 2003)

**REFERENCES:**

- a) 747 In-Service Activity Report (ISAR) 97-14-5755-14, dated 17 October 1997
- b) Overhaul Manual (OHM) 57-52-31
- c) 747-400 Illustrated Parts Catalog (IPC) 27-51-02-2, Item 235
- d) 747 IPC 57-52-07-3, Item 295

## SUMMARY:

This service letter advises operators of an improved design to the inboard fore flap link assembly. The design of the 65B17540 fore flap link assembly is improved to enhance its corrosion resistance.

## BACKGROUND:

During a revenue flight an operator experienced the partial loss of the right wing inboard trailing edge (TE) fore flap during climb-out. The damaged fore flap was discovered during descent when the TE flaps were deployed in preparation for landing (the fore flap is completely stowed within the wing trailing edge during cruise). An uneventful landing was made.

A detailed inspection of the airplane found significant secondary damage in the fore flap area, as well as minor impact damage to the horizontal stabilizer leading edge, wing-to-body fairing, and over-wing slide door.

The inboard (P/N 65B17540-3) of the two fore flap attach fittings was found fractured and is considered the cause of the partial fore flap loss. Refer to Reference c) or d).

**DISCUSSION:**

Boeing received three prior reports of 65B17540-3 fore flap link assembly fracture. No parts departed the airplane during two of the prior events. However, during the reference a) fitting fracture event in 1997, partial loss of the inboard fore flap did occur in a manner similar to the most recent event.

Boeing conducted a metallurgical analysis of the fractured fittings from the three prior events and found indications of Stress Corrosion Cracking (SCC) at the bore surface for each of the fittings.

Fracture of the inboard fore flap link assembly does not necessarily cause partial fore flap loss to occur. As a result of the design, it is possible for the fore flap to remain functional for an indeterminate amount of time with the 65B17540 link assembly fractured.

Loss of the fore flap is not considered to be critical for safety of flight.

**BOEING ACTION:**

Boeing improved the design of the link assembly to enhance its corrosion resistance. The improved link assembly, P/N 65B17540-5, is incorporated on airplane Line Position 1335. The P/N 65B17540-5 link assembly is applicable to right and left wing inboard fore flap assemblies.

**SUGGESTED OPERATOR ACTION:**

Boeing recommends operators replace existing P/N 65B17540-3 with P/N 65B17540-5 link assemblies at a convenient maintenance opportunity such as during flap overhaul per Reference b).

**WARRANTY INFORMATION:**

Boeing warranty remedies are not available for the configuration change discussed in this service letter.

**INTERCHANGEABILITY:**

The improved P/N 65B17540-5 link assembly is fully interchangeable with the existing P/N 65B17540-3 link assembly.

**PARTS AVAILABILITY:**

Link Assembly P/N 65B17540-5 will be available from Boeing in November 2003. Consult the Boeing spares account representative for price and delivery information.

747-SL-57-097  
14 November 2003  
Page 3 of 3

**RELATED INFORMATION:**

There are no published repairs for the P/N 65B17540-(\*) link assembly in Reference b). There are also no oversize bearings available for this part because fittings with corrosion indications are generally not suitable for continued use.

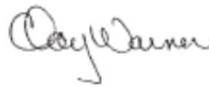
A handwritten signature in black ink, appearing to read 'Clay Warner', written in a cursive style.

Clay D. Warner  
747 Fleet Support Chief

SMH:vgs

Attachment: Inboard Fore Flap Link Assembly Fracture

ATTACHMENT To: 747-SL-57-097  
14 November 2003  
Page 1 of 1

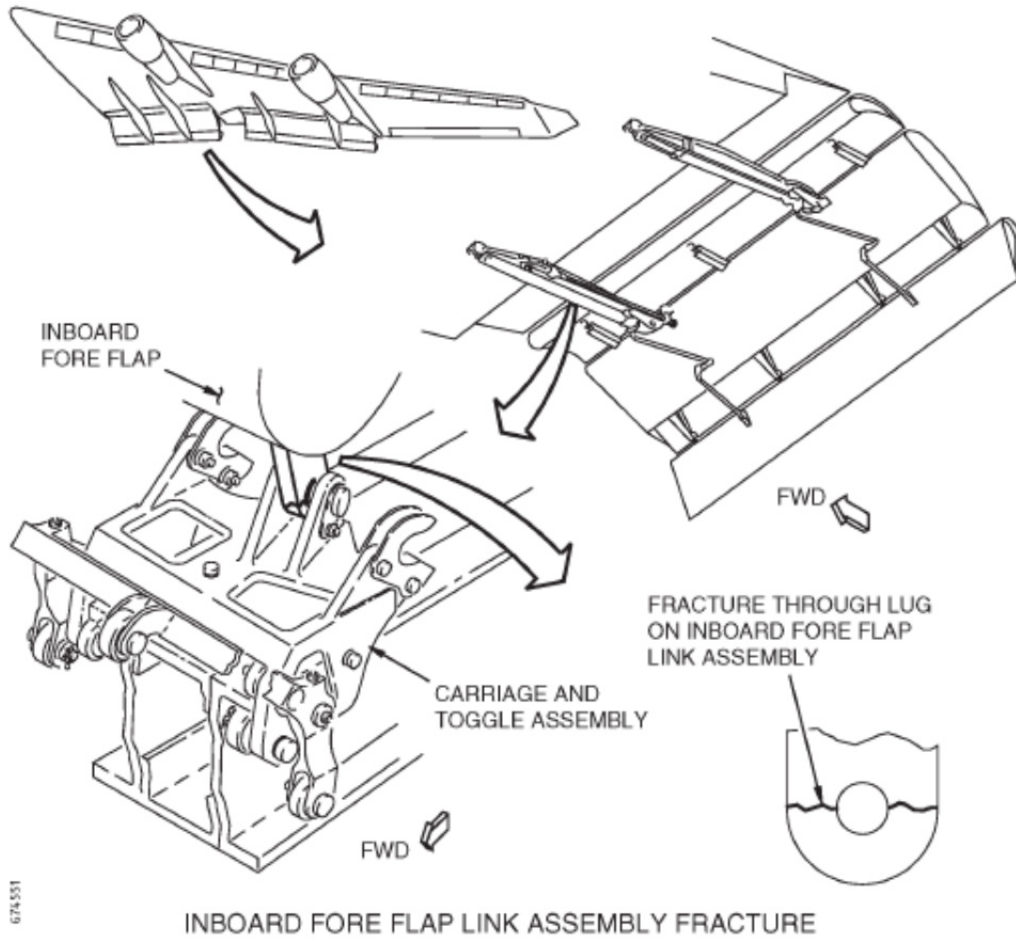

This investigation was conducted in accordance with the regulation (EU) No. 996/2010 of the European Parliament and of the Council of 20 October 2010 on the investigation and prevention of accidents and incidents in civil aviation and the Federal German Law relating to the investigation of accidents and incidents associated with the operation of civil aircraft (*Flugunfall-Untersuchungs-Gesetz - FIUUG*) of 26 August 1998.

The sole objective of the investigation is to prevent future accidents and incidents. The investigation does not seek to ascertain blame or apportion legal liability for any claims that may arise.

This document is a translation of the German Investigation Report. Although every effort was made for the translation to be accurate, in the event of any discrepancies the original German document is the authentic version.

## Published by:

Bundesstelle für  
Flugunfalluntersuchung  
Hermann-Blenk-Str. 16  
38108 Braunschweig

Phone           +49 531 35 48 - 0  
Fax              +49 531 35 48 - 246

Mail             [box@bfu-web.de](mailto:box@bfu-web.de)  
Internet        [www.bfu-web.de](http://www.bfu-web.de)