



United Arab Emirates



الهيئة العامة للطيران المدني  
GENERAL CIVIL AVIATION AUTHORITY

# Air Accident Investigation Sector

Incident

- Final Report -

AIFN/0008/2014

## Smoke Emission from Passenger Entertainment System Video Display Unit

Operator: Flydubai  
Type: Boeing 737-800  
Registration: A6-FEK  
Location: Enroute Dubai to Kiev  
Date of Occurrence: 19 April 2014



الهيئة العامة للطيران المدني  
GENERAL CIVIL AVIATION AUTHORITY

Air Accident Investigation Sector  
General Civil Aviation Authority  
The United Arab Emirates

## Incident Brief

|  |   |
|--|---|
| <b>GCAA AAI Report No.:</b>            | AIFN/0008/2014                          |
| <b>Operator:</b>                       | Flydubai                                |
| <b>Aircraft Type and Registration:</b> | Boeing 737-800, A6-FEK                  |
| <b>MSN</b>                             | 40282                                   |
| <b>Number and Type of Engines:</b>     | Two, CFMI CFM56-7B27E, Turbofan engines |
| <b>Date and Time (UTC):</b>            | 19 April 2014                           |
| <b>Location:</b>                       | Dubai                                   |
| <b>Type of Flight:</b>                 | Commercial, passenger                   |
| <b>Persons Onboard:</b>                | 66                                      |
| <b>Injuries:</b>                       | None                                    |

## Investigation Objective

This Investigation is performed pursuant to the United Arab Emirates (UAE) Federal Act 20 of 1991, promulgating the Civil Aviation Law, Chapter VII, Aircraft Accidents, Article 48. It is in compliance with Part VI, Chapter 3 of the UAE Civil Aviation Regulations, in conformity with *Annex 13 to the Convention on International Civil Aviation* and in adherence to the *Air Accidents and Incidents Investigation Manual*.

*The sole objective of this Investigation is to prevent aircraft accidents and incidents. It is not the purpose of this activity to apportion blame or liability.*

## Investigation Process

The occurrence involved a Boeing 737-800 passenger Aircraft, registration A6-FEK, and was notified to the General Civil Aviation Authority (GCAA) by phone call to the Duty Investigator (DI) Hotline Number +971 50 641 4667.

After the Initial/On-Site Investigation phase, the occurrence was classified as an 'Incident'.

An Investigation Team was formed in line with the Annex 13 obligations of the UAE being the State of Registry.

The scope of the Investigation into this Incident is limited to the events leading up to the occurrence; no in-depth analysis of non-contributing factors was undertaken.



Notes:

- 1 Whenever the following words are mentioned in this Report with the first letter Capitalized, it shall mean:
  - (Aircraft)- the aircraft involved in this Incident.
  - (Investigation)- the investigation into this Incident
  - (Incident)- this investigated Incident
  - (Report)- this Incident Report
- 2 Unless otherwise mentioned, all times in this Report are Coordinated Universal Time (UTC), (UAE Local Time minus 4).
- 3 In this Report, the word 'Cockpit' and 'Flight Deck' are synonyms.
- 4 Photos used in the text of this Report are taken from different sources and are adjusted from the original for the sole purpose to improve clarity of the Report. Modifications to images used in this Report are limited to cropping, magnification, file compression, or enhancement of color, brightness, contrast or insertion of text boxes, arrows or lines.

## Abbreviations and Definitions

|              |  |
|--------------|--|
| <b>AAIS</b>  | Air Accident Investigation Sector                            |
| <b>AC</b>    | Alternating current  |
| <b>ACP</b>   | Attendant Control Panel                                      |
| <b>ADIRS</b> | Air Data Inertial Reference System                           |
| <b>ADU</b>   | Aircraft Data Unit   |
| <b>AIFN</b>  | Accident/incident file number                                |
| <b>AIU</b>   | Aircraft Interface Unit                                      |
| <b>ATPL</b>  | Airline Transport Pilot License                              |
| <b>ATS</b>   | Air Traffic Service  |
| <b>CARs</b>  | Civil Aviation Regulations                                   |
| <b>CCA</b>   | Circuit card assembly  |
| <b>CCM</b>   | Cockpit Crewmember   |
| <b>CCFL</b>  | Cold-Cathode Fluorescent                                     |
| <b>CLU</b>   | Content Loader Unit  |
| <b>CoA</b>   | Certificate of Airworthiness                                 |
| <b>CoR</b>   | Certificate of Registration                                  |
| <b>CRM</b>   | Crew Resources Management                                    |
| <b>DI</b>    | Duty Investigator  |
| <b>D-SUB</b> | Electrical connector   |
| <b>FAA</b>   | Federal Aviation Administration                              |
| <b>FO</b>    | Fiber Optic  |
| <b>FMCS</b>  | Flight Management Computer System                            |
| <b>GCAA</b>  | General Civil Aviation Authority of the United Arab Emirates |
| <b>HDMI</b>  | High Definition Multimedia Interface                         |
| <b>HDD</b>   | Hard Drive Disc  |
| <b>ICAO</b>  | The International Civil Aviation Organization                |
| <b>IFE</b>   | In-Flight Entertainment                                      |
| <b>LCD</b>   | Liquid-Crystal Display                                       |
| <b>LED</b>   | Light-Emitting Diode   |
| <b>MDL</b>   | Master Drawing List  |



الهيئة العامة للطيران المدني  
GENERAL CIVIL AVIATION AUTHORITY

|             |                                |
|-------------|--------------------------------|
| <b>MSN</b>  | Manufacturer Serial Number     |
| <b>MPSU</b> | Monitor Power Supply Unit      |
| <b>No.</b>  | Number                         |
| <b>PA</b>   | Passengers Address             |
| <b>PBE</b>  | Protective breathing equipment |
| <b>PCB</b>  | Printed circuit board          |
| <b>PCU</b>  | Passenger Control Unit         |
| <b>PCM</b>  | Power Control Module           |
| <b>PF</b>   | Pilot Flying                   |
| <b>PH</b>   | Pilot Handling                 |
| <b>PIM</b>  | Passenger Interface Module     |
| <b>PM</b>   | Pilot Monitoring               |
| <b>P/N</b>  | Part Number                    |
| <b>QRH</b>  | Quick Reference Handbook       |
| <b>SDB</b>  | Secure Data Bridge             |
| <b>S/N</b>  | Serial Number                  |
| <b>CVR</b>  | Cockpit voice recorder         |
| <b>FDR</b>  | Flight data recorder           |
| <b>SSU</b>  | Server Switch Unit             |
| <b>STC</b>  | Supplemental Type Certificate  |
| <b>STP</b>  | Set Top Box                    |
| <b>UAE</b>  | The United Arab Emirates       |
| <b>USB</b>  | Universal Serial Bus           |
| <b>UTC</b>  | Coordinated Universal Time     |
| <b>Vac</b>  | Volts- alternating current     |
| <b>Vdc</b>  | Volts- direct current          |
| <b>VDU</b>  | Video Display Unit             |



## Synopsis

On 19 April 2014, during the descent of Flydubai Boeing 737-800, registration A6-FEK, to Kiev Boryspil International Airport, Ukraine, at approximately 15,000 feet altitude, the visual display unit (VDU) of the In-Flight Entertainment (IFE) system at seat 9A started to emit smoke. Accordingly, the cabin crewmember moved the passengers seated in 9A, 9B and 9C to other locations.

The cabin supervisor switched off the power to the IFE system and advised the flight crew of the situation by interphone. Another cabin crewmember obtained a fire extinguisher and smoke hood from the forward cabin and discharged the contents of the fire extinguisher in several applications until the smoke diminished.

The captain, who was the Pilot Monitoring (PM), contacted Kiev Air Traffic Control (ATC) and declared a "mayday". The captain commenced the '*Smoke, Fire, Fumes*' checklist in the *Quick Reference Handbook (QRH)*. While completing the checklist, the cabin supervisor called informing him that the smoke had stopped and dissipated.

The captain resumed his normal PM duties and handled ATC communications until the Aircraft landed uneventfully.

The Air Accident Investigation Sector (AAIS) determines that the causes of the smoke that emitted from the VDU of seat 9A were: Gasses emitted from the printed circuit board (PCB) of the VDU backlight inverter board; the heat caused by increased current demand after the break in the secondary coil of the transformer followed by the failure of the primary side transistor components; and the failure of the fuse to open quickly and isolate the circuit due to its inappropriate rating related to the VDU application and possibly other reasons not determined by the Investigation.

A Contributing Factor to the Incident was that the material of the fuse might have helped in transferring heat by 'conduction' between the fuse and the PCB of the backlight inverter board.

Four safety recommendations are included in this Report. Two recommendations to the operator, to: ship any removed VDU to the manufacturer for replacement of the fiberglass substrate material fuse by a ceramic body, suspended-in-air filament fuse; and for any future orders for any aircraft type equipped with similar VDU part number, to ensure that the VDU is of the modified LED backlight or modified open-to-air fuse standard.

Two safety recommendations are issued to the General Civil Aviation authority (GCAA) of the United Arab Emirates, to: ensure that any future Supplemental Type Certificate (STC) relevant to IFE installation on any UAE-registered aircraft refers in the 'materials required' section to the modified VDU; and disseminate the information included in this Report to all UAE operators for their proactive action in relation to any existing affected VDUs or for the addition of aircraft to their fleets equipped with similar part number VDUs.

# CONTENTS

|  |     |
|--|-----|
| Incident Brief .....   | i   |
| Investigation Objective .....                                  | i   |
| Investigation Process .....                                    | i   |
| Abbreviations and Definitions .....                            | iii |
| Synopsis .....   | v   |
| 1. Factual Information .....                                   | 1   |
| 1.1 History of the Flight .....                                | 1   |
| 1.2 Injuries to Persons .....                                  | 2   |
| 1.3 Damage to Aircraft .....                                   | 2   |
| 1.4 Other Damage .....   | 2   |
| 1.5 Personnel Information .....                                | 4   |
| 1.6 Aircraft Information .....                                 | 4   |
| 1.6.1 Aircraft Data .....                                      | 4   |
| 1.6.2 Engine Data .....  | 5   |
| 1.6.3 IFE System .....   | 5   |
| 1.6.4 Video Display Unit (VDU) Description and Operation ..... | 6   |
| 1.6.6 VDU modification history .....                           | 9   |
| 1.6.6 VDU maintenance history .....                            | 9   |
| 1.7 Meteorological Information .....                           | 10  |
| 1.8 Aids to Navigation .....                                   | 10  |
| 1.9 Communications .....                                       | 10  |
| 1.10 Aerodrome Information .....                               | 10  |
| 1.11 Flight Recorders .....                                    | 11  |
| 1.12 Wreckage and Impact Information .....                     | 11  |
| 1.13 Medical and Pathological Information .....                | 11  |
| 1.14 Fire .....  | 11  |
| 1.15 Survival Aspects .....                                    | 11  |
| 1.16 Tests and Researches .....                                | 12  |
| 1.16.1 VDU Teardown Report .....                               | 12  |



|        |  |    |
|--------|--|----|
| 1.17   | Organisational and Management Information .....                        | 15 |
| 1.18   | Additional Information .....   | 16 |
| 1.18.1 | Interior Reconfiguration.....  | 16 |
| 1.18.2 | VDUs Maintenance Practices and Continuing Airworthiness.....           | 17 |
| 1.19   | Useful or Effective Investigation Techniques.....                      | 17 |
| 2.     | Analysis .....   | 18 |
| 2.1    | In-Flight Entertainment System (IFE) .....                             | 18 |
| 2.2    | Emergency Handling .....   | 18 |
| 3.     | Conclusions .....  | 20 |
| 3.1    | General.....   | 20 |
| 3.2    | Findings.....  | 20 |
| 3.3    | Causes .....   | 21 |
| 3.4    | Contributing Factors to the Incident .....                             | 21 |
| 4.     | Safety Recommendations .....   | 22 |
| 4.1    | General.....   | 22 |
| 4.2    | Safety Actions Taken.....  | 22 |
| 4.3    | Final Report Safety Recommendations.....                               | 22 |
| 4.3.1  | The operator .....   | 22 |
| 4.3.2  | The General Civil Aviation Authority of the United Arab Emirates ..... | 23 |



# 1. Factual Information

## 1.1 History of the Flight

On 9 April 2014, during the descent of Flydubai Boeing 737-800, registration A6-FEK, to Kiev Boryspil International Airport, Ukraine, at approximately 15,000 feet altitude, three hi-low chimes were heard coming from row 9. A cabin crew member (CCM) observed that the visual display unit (VDU) of the In-Flight Entertainment (IFE) system at seat 9A was emitting smoke. The CCM moved the passengers seated in 9A, 9B and 9C to other locations.

The cabin supervisor was informed immediately of the situation and she switched off the power to the IFE system and advised the flight crew using the interphone.

A CCM obtained a fire extinguisher and smoke hood from the forward cabin. He donned the smoke hood and proceeded to seat 9A where the VDU was emitting smoke accompanied by a "crackling" noise. The CCM discharged the contents of the fire extinguisher in several applications. A second extinguisher was obtained but was not used as the CCM observed that the volume of smoke being emitted by the VDU was diminishing.

A passenger announcement was made informing the passengers that the situation was safe and that the Aircraft would land normally at the destination airport.

The captain, who was the Pilot Monitoring (PM) had received the first message from the cabin supervisor informing him that there was increasing heavy smoke and fumes in the cabin indicating an electrical fire. On the captain's instruction, the cabin supervisor checked the source of the smoke and informed the captain that the smoke was coming from the IFE.

The captain stated that he could see on the cabin observation camera screen in the cockpit that a CCM was wearing personal breathing equipment (PBE). The captain switched off the IFE. This action also switched off the camera since the IFE and the camera are on the same electrical bus.

The captain instructed the cabin supervisor to continue fighting the fire and keep him informed of any changes in the situation. The captain told the co-pilot that he would declare an emergency. He contacted Kiev air traffic control (ATC) and informed the controller that there was smoke in the cabin and he declared a "mayday".

The ATC offered Kyiv Boryspil International Airport (UKBB) as an alternate but the captain stated that he "declined as we were set up and briefed for [Zhuliany International Airport] (UKKK) and minutes from landing". The crew briefly discussed the possibility of a straight in approach to runway 26 at UKKK but the wind favored runway 08.

The captain stated that the co-pilot remained as Pilot Flying (PF) and handled ATC communications. The captain commenced the '*Smoke, Fire, Fumes*' checklist in the *Quick Reference Handbook (QRH)*. While completing the checklist, the cabin supervisor called informing him that the smoke had stopped and dissipated.

The captain provided a NITS<sup>1</sup> briefing to the cabin supervisor and asked if the cabin was secure. The cabin supervisor replied that she would need one more minute to secure the cabin.

The captain completed the checklist and then the cabin supervisor called back advising him that cabin was now secure. The captain resumed his normal PM duties and handled ATC communications for landing.

After landing, the captain informed ATC that the aircraft would proceed normally to the gate.

The passengers were disembarked normally without injury.

## 1.2 Injuries to Persons

**Table 1.** Injuries to persons

| Injuries     | Flight Crew | Cabin Crew | Other Crew Onboard | Passengers | Total Onboard | Others   |
|--------------|-------------|------------|--------------------|------------|---------------|----------|
| Fatal        | 0           | 0          | 0                  | 0          | 0             | 0        |
| Serious      | 0           | 0          | 0                  | 0          | 0             | 0        |
| Minor        | 0           | 0          | 0                  | 0          | 0             | 0        |
| None         | 2           | 5          | 0                  | 59         | 66            | 0        |
| <b>TOTAL</b> | <b>2</b>    | <b>5</b>   | <b>0</b>           | <b>59</b>  | <b>66</b>     | <b>0</b> |

There were no injuries to persons as a result of the Incident.

## 1.3 Damage to Aircraft

The aircraft was undamaged with the exception of damage to the VDU that had emitted smoke.

## 1.4 Other Damage

There was no other damage to property and/or the environment.

<sup>1</sup> **NITS:** Nature of the emergency  
Intentions of the crew  
Time available  
Supplementary information

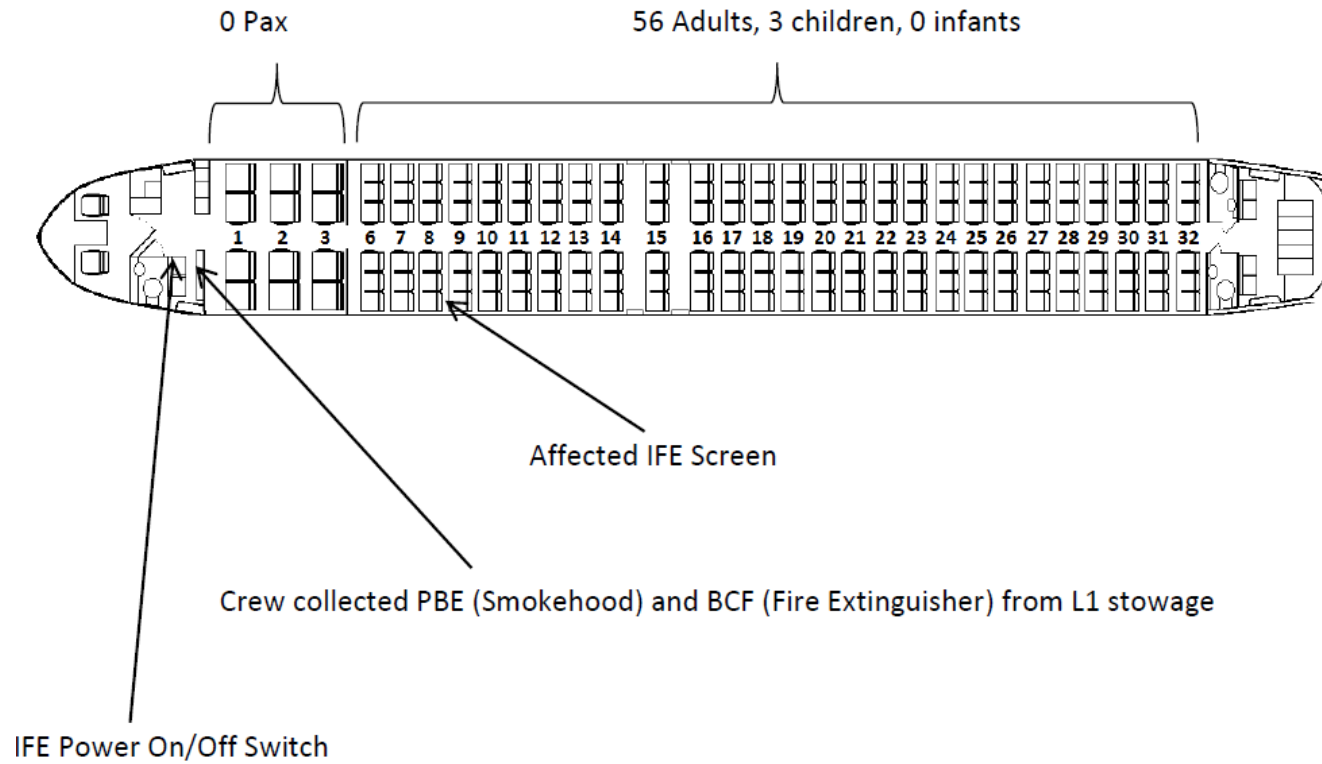

Figure 1. Aircraft configuration

## 1.5 Personnel Information

Table 2 illustrates the captain and co-pilot information current at the time of the Incident.

| Table 2. Crew information |                          |                          |
|---------------------------|--------------------------|--------------------------|
|                           | Captain                  | Co-pilot                 |
| Age                       | 33                       | 46                       |
| Gender                    | Male                     | Male                     |
| License                   | ATPL                     | ATPL                     |
| Valid to                  | 14 March 2019            | 8 December 2017          |
| Issuing State             | The United Arab Emirates | The United Arab Emirates |
| Rating                    | Boeing 737-800           | Boeing 737-800           |
| Total flying time         | 7,500 hours              | 18,226 hours             |
| Total flying time on type | 3,580 hours              | 3,454 hours              |
| Medical class             | One                      | One                      |
| Valid to                  | 4 April 2015             | 31 May 2014              |
| Medical limitation        | None                     | None                     |

Flight crew experience information was not relevant to the Incident.

## 1.6 Aircraft Information

### 1.6.1 Aircraft Data

Table 3 illustrates general information about the Aircraft as of the date of the Incident.

| Table 3. Aircraft data |         |
|------------------------|---------|
| Manufacturer:          | Boeing  |
| Model:                 | 737-800 |

|                                     |   |
|-------------------------------------|---|
| MSN:                                | 40282                                     |
| Date of manufacture:                | 20 December 2013                          |
| Nationality and registration mark:  | The United Arab Emirates, A6-FEK          |
| Name of the owner:                  | AL TWAR ONE LIMITED                       |
| Name of the operator:               | Flydubai                                  |
| Certificate of Airworthiness (CoA)  |   |
| Number:                             | UAE-COA-0196                              |
| Issue date:                         | 20 December 2013                          |
| Valid to:                           | ARC-FD-FEK-01<br>Due 19 December 2014     |
| Certificate of Registration (CoR)   |   |
| Number:                             | UAE-COR-0630                              |
| Issue date:                         | 20 December 2013                          |
| Valid to:                           | Open                                      |
| Date of delivery                    | 21 December 2013                          |
| Total hours since new (TSN)         | 1,239                                     |
| Total cycles since new (CSN)        | 513                                       |
| Last inspection and date:           | Phase 1 and Phase 2 Checks, 22 March 2014 |
| Total hours since last inspection:  | 318                                       |
| Total cycles since last inspection: | 132                                       |

### 1.6.2 Engine Data

Table 4 illustrates general information about the engines.

| Table 4. Engine data |                          |
|----------------------|--------------------------|
| Engine type:         | Turbofan                 |
| Manufacture:         | Joint SNECMA-GE Aviation |
| Type:                | CFMI CFM56-7B27E         |

The engines were not relevant to this Incident.

### 1.6.3 IFE System

The Aircraft was equipped with the IFE system during production. The IFE system installed on the Aircraft consists of seven parts:

- Server Switch Unit (SSU) which contains the content streaming processor, Hard Drive Disc (HDD) storage for content, Ethernet switch chips, and fiber optic transceivers.

- Video Display Unit (VDU) which connects to the Server Switch Unit (SSU) or the next VDU in the chain by fiber optic cabling.
- Secure Data Bridge (SDB) provides credit card data storage and communication via cellphone network when the aircraft is on the ground.
- Aircraft Interface Unit (AIU) provides passenger address (PA) microphone interface to the fiber optic (FO) network.
- Content Loader Unit (CLU) provides background loading of content during normal system operation.
- The Monitor Power Supply Unit (MPSU)- a remote-mounted unit that provides power to up to 15 seat displays.
- Aircraft Data Unit (ADU) contains an ARINC 429 Interface with the aircraft Flight Management Computer System (FMCS) and Air Data Inertial Reference System (ADIRS) for map display.

#### 1.6.4 Video Display Unit (VDU) Description and Operation

The VDU is an 8.9-inch Liquid-Crystal Display (LCD) with a 16x9 aspect ratio, 1024x600 resolution, and a touch-screen controller. The VDU has a front-panel passenger-accessible audio headset jack and a Universal Serial Bus (USB) port. All passenger control is by way of touchscreen. No separate Passenger Control Unit (PCU) is necessary. The VDU is capable of displaying high definition and standard definition video.

The same VDU can be installed in a seatback, armrest, be bulkhead mounted, or be installed in the galley area of the aircraft. The VDU interfaces with the SSU or the previous VDU in the chain via a single fiber, and provides a second fiber to the next VDU in the chain. It receives +28 Vdc power from the MPSU.

The VDU has the following major functional features:

- Media Converter circuitry
- Set top box controller
- PA-VDU controller circuitry
- LCD controller circuitry
- LCD panel with touchscreen
- Backlight inverter
- Power supply circuitry
- Credit card reader assembly
- Audio headphone jack
- USB jack
- Pushbutton passenger controls

Figure 2 illustrates a block diagram of the IFE. Figure 3 illustrates the controls, indicators, and connections of the component, as applicable.

The VDU has a High Definition Multimedia Interface (HDMI) from the Set Top Box (STB) printed circuit board (PCB) to the LCD controller. Digital audio is decoded from the HDMI data stream and converted to analog audio for output on the front panel audio headphone jack.

On the -002 VDU only, pushbuttons are provided for attendant call and reading light ON/OFF control over Ethernet to the aircraft data system. Power output to the USB connector is enabled or disabled through software activation based on credit card purchase.

Temperature monitoring is active to monitor the internal VDU temperature.

Microphone input for passenger chat and gaming communications is provided by the Daughter PCB. Analog microphone input is converted to digital PCM audio format. The Daughter PCB also provides circuitry for digital video input for webcam input and analog NTSC outputs to drive external monitors. The Fiber Optic port connectors provide the interface from the System Server Units (SSUs).

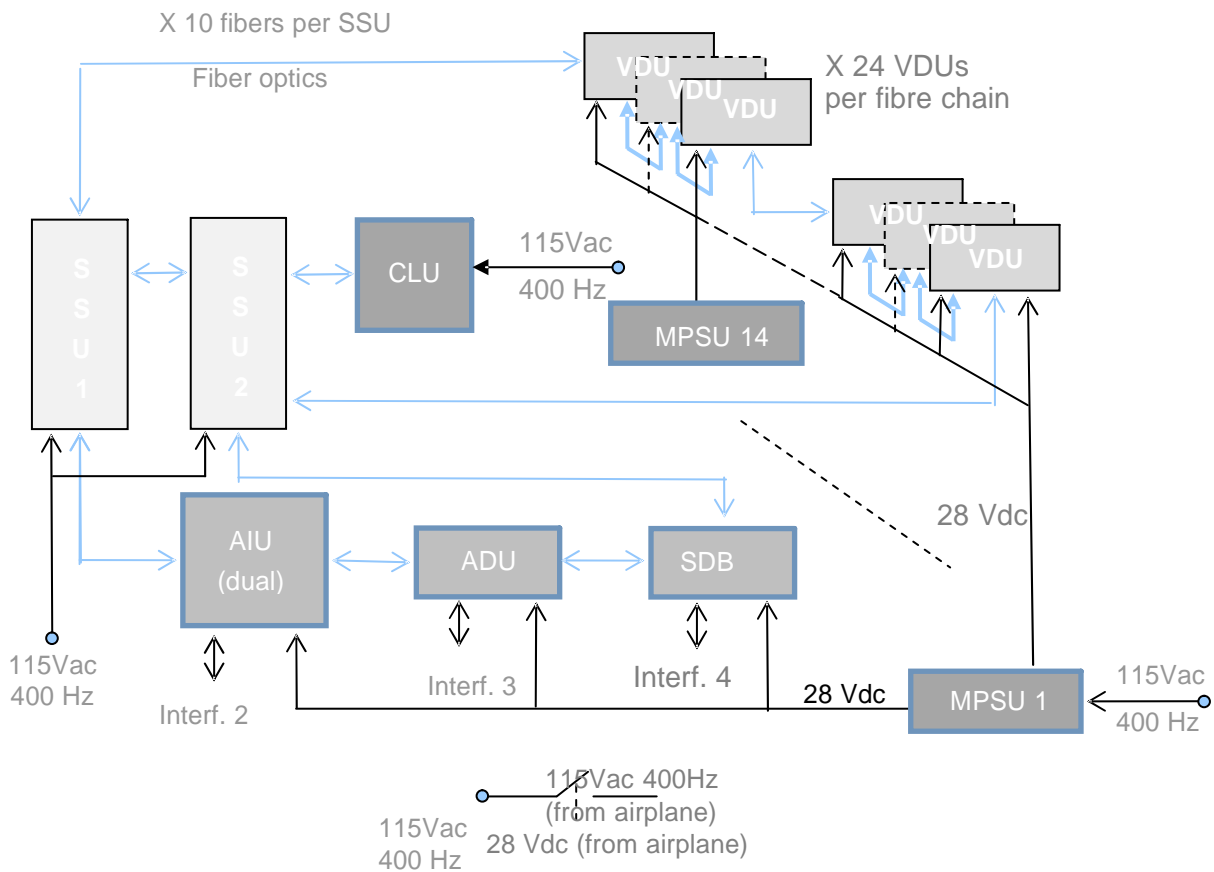

Figure 2. IFE System Block Diagram

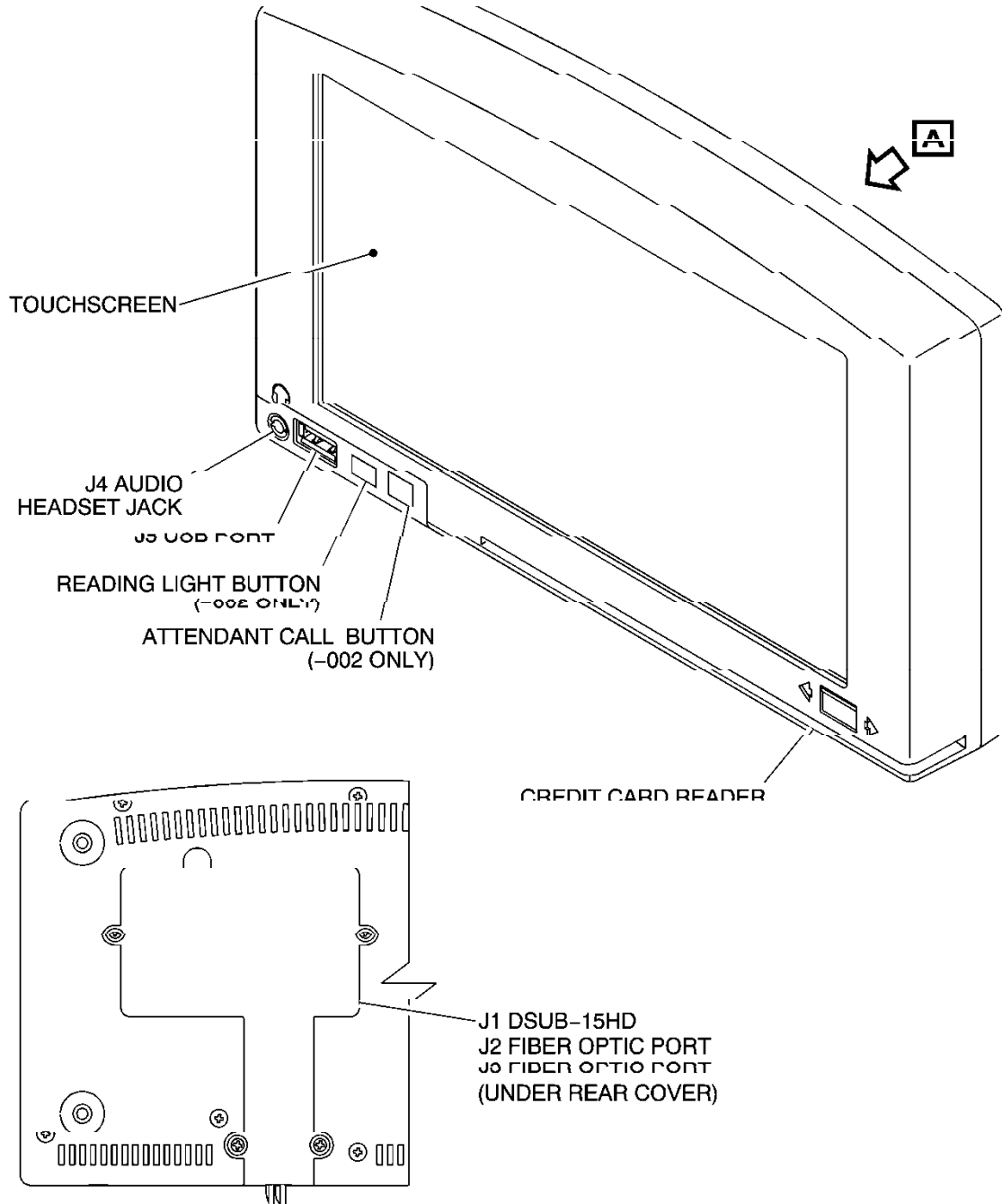

Figure 3. VDU illustration

### 1.6.6 VDU modification history

The modification history of the affected VDU part number (P/N) 100-2002-00X shows that the current revision number of the 'Drawing Release/Change Notice of Drawing' is B. MOD-100-2002-001, resulting in Revision D added modification 5 which is implemented with Final Assembly 100-2002-100 L in the next production build. A note included in the modification stated that, "Revision C intentionally skipped as an earlier mod [modification] was previously cancelled".

The modification, which was released on 15 July 2013, was intended to provide an additional insulation barrier to prevent foreign particles from contaminating the cable pins mated to the Passenger Interface Module (PIM) interconnect board assembly by adding RTV 5242<sup>2</sup> to the mated PIM flex cable P2 end and PIM interconnect board connector J14A.

The instructions for the already fielded units was for any VDU returned from the field for repair be modified (MOD 5) to include the insulation barrier to prevent foreign particles from contaminating the flex cable pins mated to the PIM interconnect board assembly. The modification states that, "the reason for change was to improve insulation barrier for flex cable connection".

### 1.6.6 VDU maintenance history

The approved maintenance program of the operator calls for visual inspection of each seat mounted, galley mounted, galley and bulkhead mounted VDU to ensure to ensure that the VDU and attachments (where visible) are intact, and that the headphone jack, USB port, and credit card slot are unobstructed. The interval of the inspection is 4000 cycles or 22 months, whichever comes first.

Table 5 illustrates a summary of the IFE previously reported defects

**Table 5. Summary of IFE related reported defects**

| No. | Defect date   | Report  | status |
|-----|---------------|---|--------|
| 1   | 19 April 2014 | During descent, thick white smoke came from IFE at 9A. Cabin crew used 1 BCF and 1 PBE to extinguish. IFE switched off from flt deck, fire  | Closed |
| 2   | 23 March 2014 | Perform IFE SW upgrade/April 2014 content load IAW SIL-FZ-048 N/C install the CLU drive cartridge P/N 100-6010-001 IAW [in accordance with] AMM [Aircraft maintenance manual] procedure | Closed |

<sup>2</sup> RTV5240 series sealants are alkoxy neutral cure, one-component, ready to use, electronic grade silicone adhesive sealants exhibiting high strength that will maintain a strong bond even when exposed to moist environments. RTV5240 series sealant are true neutral curing silicone sealants that release methyl alcohol during cure while exposed to atmospheric moisture at room temperature

|    |                  |   |        |
|----|------------------|---|--------|
| 3  | 28 February 2014 | 21 ABC and 31 DEF IFE screens are not working BITE C/O [carried out]. Reset Satis. [Satisfactory]. CMM [component maintenance manual] 44-24-10. | Closed |
| 4  | 24 February 2014 | SWR<br>Update IFE system with new content.  | Closed |
| 5  | 12 February 2014 | From C.L.B. NO 17193 screens at row 7 ABC remain switched off. Reset several times but still unserviceable.                                     | Closed |
| 6  | 5 February 2014  | SWR<br>PERFORM IFE SOFTWARE UPGRADE IAW SIL-FZ-047 N/C  | Closed |
| 7  | 26 January 2014  | SWR<br>Update IFE system with new content.  | Closed |
| 8  | 6 January 2014   | IFE FAP has a real break on L/H side. Transferred to add for troubleshooting  | Closed |
| 9  | 6 January 2014   | SDB #1 (FWD [forward]) not reporting. SDB TRAY 1 not powered.   | Closed |
| 10 | 12 January 2014  |   | Closed |
| 11 | 12 January 2014  |   | Closed |
| 12 | 28 November 2013 | Perform ST04009AT (Supplemental Type Certificate) interior reconfiguration of B737-800 aircraft in accordance produced by                       | Closed |

The records revealed defects in the IFE system prior to the Incident day. The corrective action undertaken was reset the system. This did not resolve the defect on some occasions. Some of the defects were deferred for further troubleshooting.

### 1.7 Meteorological Information

The prevailing meteorological conditions were not a factor in this Incident.

### 1.8 Aids to Navigation

None of the ground-based navigation aids, onboard navigation aids, and aerodrome visual ground aids and their serviceability was a factor in this Incident.

### 1.9 Communications

The quality of the Aircraft's to Kiev ATC communication was good.

The airborne cabin-to-flight deck communication was made via the intercom system with good clarity and continuity.

### 1.10 Aerodrome Information

The airport fire and rescue services were put on standby after the captain's mayday announcement. The fire and rescue services were not required after the captain confirmed that the smoke had stopped being emitted from the VDU and the cabin was clear of smoke.

### **1.11 Flight Recorders**

The Investigation did not remove the flight data recorder (FDR) and the cockpit voice recorder (CVR) from the Aircraft.

### **1.12 Wreckage and Impact Information**

As stated in sub-section 1.3 of this Report, the aircraft was undamaged, with the exception of the VDU.”

### **1.13 Medical and Pathological Information**

No medical or pathological investigations were conducted as a result of this Incident, nor were they required.

### **1.14 Fire**

There was no sign that the smoke emitted from the VDU was due to fire neither fire was developed due to failure of the related VDU.

### **1.15 Survival Aspects**

After the Aircraft landed, the Airport Fire and Rescue Service was standing by and the tower asked the crew if they required assistance. After the captain checked with the cabin supervisor, he informed the tower that no further assistance was required, and continued to taxi uneventfully to the gate.

## 1.16 Tests and Researches

### 1.16.1 VDU Teardown Report<sup>3</sup>

The affected VDU was shipped to the manufacturer for forensic laboratory examination. According to the examination report, there were no external visible signs of smoke, fire, or other noticeable damage to the VDU. Internal damage was limited to the power transformer circuit board components and the area of the fuse that had overheated and emitted smoke and odors momentarily until power to the IFE system was shut off.

The teardown examination found that the component that had failed was the backlight inverter circuit card assembly (CCA) which provides operating power to the cold-cathode fluorescent (CCFL) backlight of the LCD display. The inverter card assembly is mounted on the main circuit card assembly as a daughter card. Its purpose is to output an alternating current (AC) high-voltage signal to power the CCFL backlight tube.

Figures 4 to 9 illustrate the VDU before removal from the back of seat 9A and the affected main circuit card and inverter circuit card assemblies.<sup>4</sup>

---

<sup>3</sup> Lumexis Tear-down Report, Video Display Unit (VDU) P/N 100-2002-001, S/N 1329006, issued on 2 May and Safety Investigation Report, issued on 23 May 2014 after joint investigation conducted by four companies: Lumexis Corporation, Endicott Research Group (ERG), Littlefuse Corporation, and Oncore Manufacturing Solutions during the time period between April 24 to May 9, 2014

<sup>4</sup> Photos were extracted from the joint Safety Investigation Report issued on 23 May 2014



Figure 4. Seat 9A VDU prior to removal

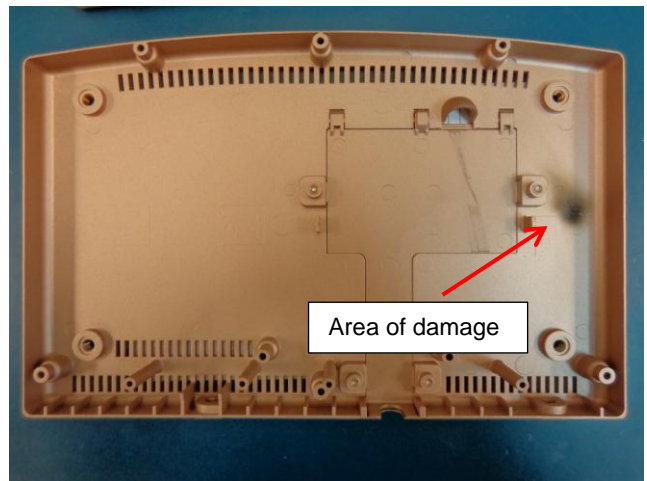

Figure 5. VDU Rear Housing - Inside



Figure 6. VDU Main CCA – bottom side

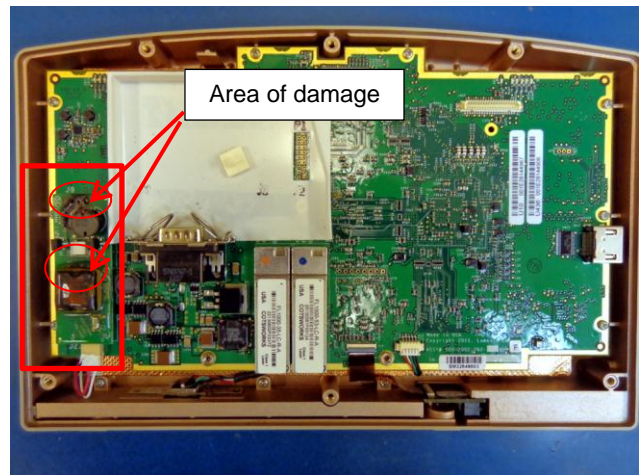
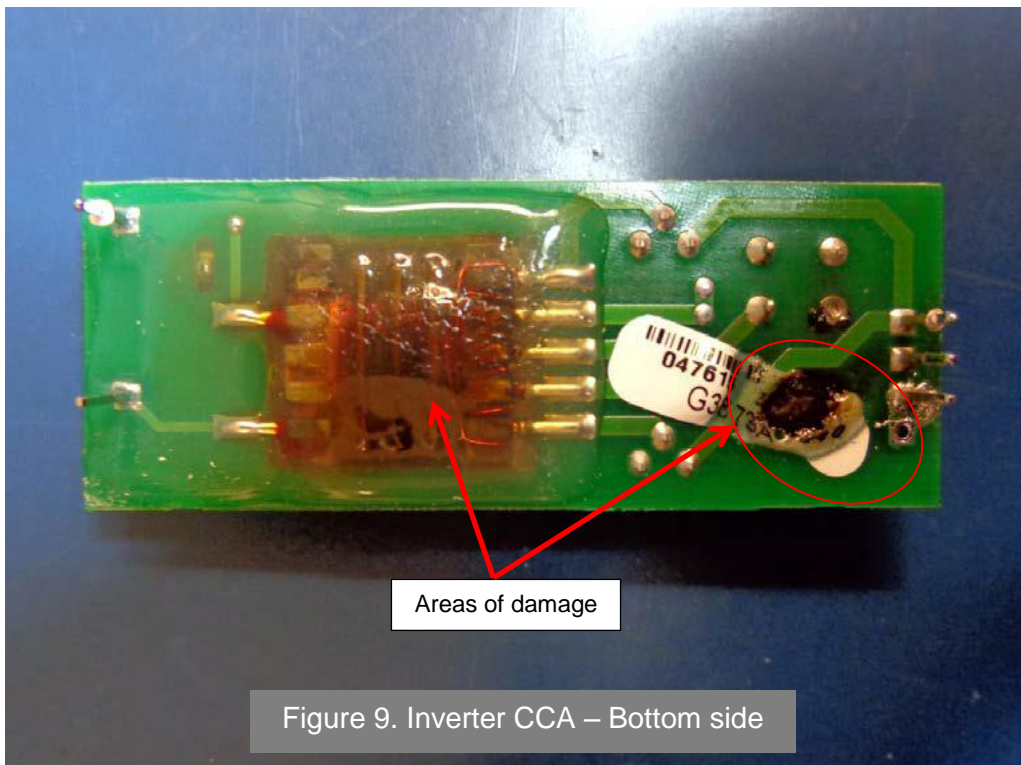
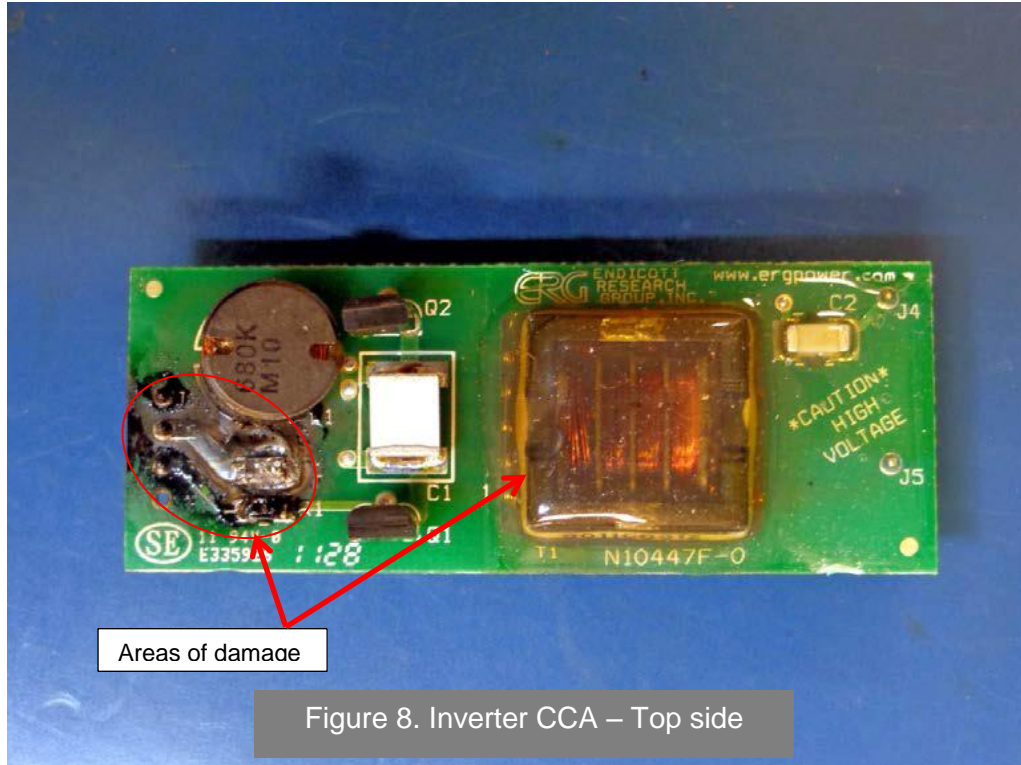

Figure 7. VDU Main CCA – top side



## 1.17 Organisational and Management Information

The operator's *Cabin Procedures Manual*, paragraph 4.19.1.3- *Smoke Development*, states that:

"The first indication that something is wrong is often the smell or sight of smoke, or a warning from a smoke detector.

Smoke is generally a mixture of fine solid particles, droplets of water and other liquids, and products given off by the materials involved in the fire. Smoke and heat will rise up to the ceiling of the cabin and then spread sideways. Disorientation is a major problem in smoke development.

Due to prevailing air currents, smoke can also travel considerable distance from the actual source of fire. The volume of smoke present will often be of no indication of the actual size of the fire as small fires can produce smoke for long periods of time in an aeroplane and can completely fill the structure with smoke This makes fire-fighting very difficult."

Paragraph 4.19.8.6- *In-Flight Entertainment Systems, Video Monitors*, states that:

"IFE fires and video monitor fires must be treated as an electrical fire. There is likely to be a smell of burning, followed by smoke, prior to any flames being present. Move passengers away from the area affected".

A flowchart of smoke recognition is illustrated in the same paragraph (Figure 10).<sup>5</sup>

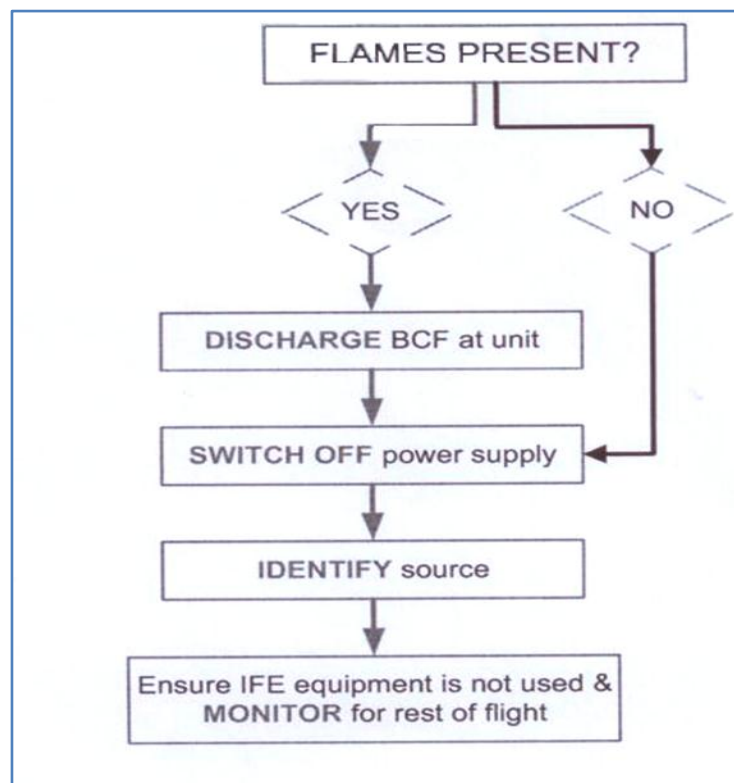

Figure 10. IFE smoke recognition flowchart

<sup>5</sup> BCF in the flowchart means 'Bromochlorodifluoromethane', also known by the trade name Halon 1211, or BCF, or Halon 1211 BCF, or Freon 12B1, is a haloalkane with the chemical formula  $CF_2ClBr$

Paragraph 4.19.8.11- *Smoke and Fumes in the Cabin*, states that:

"Smoke is a by-product of fire and if there is no visual sign of flames, the surrounding area should be checked for presence of heat. If heat is found, remove all combustible materials

The flight crew must be informed immediately via the interphone of the sources, colour and quantity of smoke and passenger reaction.

WARNING: The flight deck door must be kept closed.

Should smoke make breathing difficult or become excessive, the flight crew may vent the cabin by increasing the air-conditioning flow rate. Alternatively, they may adjust the opposite; a minimum of ventilation in order to starve the fire of oxygen

WARNING: Smoke removal procedures should not be requested unless absolutely necessary, as an increase in ventilation is required to clear the smoke, whereas fire-fighting procedures require cabin altitude/pressurisation rate selectors and open various outflow valves.

If the increase in cabin ventilation is not adequate to dissipate the smoke, the Commander will consider landing at the nearest airport. Cabin crew should prepare for an emergency evacuation.

Where smoke in the cabin makes it difficult to breathe, instruct passengers to lean over, keeping their heads low and breathe through a blanket, headrest cover, handkerchief, etc. If possible, distribute wet towels/handkerchiefs/materials and ask passengers to "get down on the floor and cover their mouth and nose with the aforementioned wet items".

## 1.18 Additional Information

### 1.18.1 Interior Reconfiguration

Although the IFE system was installed on the Aircraft during production, other aircraft in the operator's Boeing 737 fleet had gone through in-service IFE modification. The modification was accomplished by TIMCO Aerosystems Master Data List (MDL) No. 12T478L001- *Interior Reconfiguration* Revision IR dated 8 August 2013. Specifically, galleys, dividers and windscreen VDU installation was done according to TIMCO Drawing 12T478V042- *VDU Installation* assigning TIMCO P/Ns 100-2010-series and 100-2013-series for the 10.1 and 12.1-inch VDUs, respectively.

The governing master document for the modification was the Supplemental Type Certificate (STC) No. ST04009AT approved by the Federal Aviation Administration (FAA) issued on 9 August 2013. TIMCO Aerosystems Instructions for Continuing Airworthiness 12T478R009, Rev. A dated 6 August 2013 is part of the STC.

### 1.18.2 VDUs Maintenance Practices and Continuing Airworthiness

In the *Continuing Airworthiness Manual* provided by TIMCO, the maintenance practices of the VDUs are: Test and calibration.

For the test, the Manual contains the following procedure:

- (a) Set the IFE/PASS SEAT switch, located on the P5 overhead panel, to the ON position.
- (b) Set the ON/OFF switch to the ON position.
- (c) At the Attendant Control Panel (ACP), enter flight attendant badge number, "2802", when prompted to log into the system.
- (d) Enter password "FD" when prompted.
- (e) At the ACP, select the MAINTENANCE mode icon.
- (f) Enter the password, "MM" when prompted.
- (g) Select the BIT icon to start the system check.
- (h) At the completion of the test, make sure that in the VDU row, 191 is displayed in the expected and present columns.

For the calibration, the Manual contains the steps (a) to (f) above and continue with the following steps:

- (g) Select the SOFTWARE icon.
- (h) Select the VDU FIRMWARE icon.
- (i) Record the latest release version number for both the Amino and Rabbit firmware.

### 1.19 Useful or Effective Investigation Techniques

No new investigation techniques were used during this Investigation.

## 2. Analysis

### 2.1 In-Flight Entertainment System (IFE)

According to the laboratory examination report, the failure developed in two stages:

Stage 1: failure of the secondary winding of the power supply transformer, which developed a break leading to increased current demand and failure of the primary side transistor components causing a low impedance path to circuit ground through the input fuse.

Stage 2: the resultant increased input current was not enough to blow the fuse open quickly, but caused the fuse itself to heat up and smolder in that area of the printed circuit board (PCB) until it eventually opened fully.

In the history of similar inverter boards produced by the same manufacturer, which had suffered transformer failures, they either did not draw excessive current, or the fuse blew open normally. The Investigation could not determine whether the unique behavior of the fuse installed in the affected Video Display Unit (VDU) was because of a fault in its fabrication or was due to a change in the properties of the fuse material due to operation over a long period of time.

The laboratory examination determined that: "The fuse trip current value was rated too high for the [application]." It was also determined that the fiberglass substrate material of the fuse might have created a media of heat transfer by 'conduction' mode since the fuse was in direct contact with the printed circuit card.

Since no traces of foreign material were found inside the VDU; the Investigation believes that the modification that was released on 15 July 2013 to provide an additional insulation barrier to prevent foreign particles from contaminating the cable pins mated to the Passenger Interface Module (PIM) interconnect board assembly, was not contributory to the smoke emitted from the VDU.

The defects history of the VDU showed that a number of IFE screens had tripped in the past including the affected VDU. The corrective actions taken were usually to re-boot or re-set the IFE system which, in most cases, resolved the defect.

### 2.2 Emergency Handling

Communications amongst the cabin crewmembers and between the cabin supervisor and the flight deck were normal with sufficient responsiveness by the crew. The emergency management was reasonable and comparable to the set procedures.

Switching off the IFE was in conformity with the *Cabin Procedures Manual* and had reduced the risk posed by the VDU failure. The manner in which the Cabin Crewmember (CCM) dealt with the smoke and the assistance he received from the other CCM maintained the integrity of their response to the emergency.

Although the cabin observation camera is not a safety requirement of the Civil Aviation Regulations (CARs) of the United Arab Emirates (UAE), the link of the camera to the same electrical bus of the IFE deprived the captain of a good source of cabin safety information that would have been more important if greater risk existed.



The captain's 'mayday' declaration was based on his judgment of the situation and was supported by the information provided by the cabin supervisor. The captain's message to the Kiev ATC that the Aircraft had smoke in the cabin, and his request for the emergency services to standby, was a proactive safety precaution.

The flight deck Crew Resources Management (CRM) was good, particularly regarding the handling of the controls and sharing the communication and checklist and responsibilities.

## 3. Conclusions

### 3.1 General

From the evidence available, the following findings, causes and contributing factors were made with respect to this Incident. These shall not be read as apportioning blame or liability to any particular organisation or individual.

To serve the objective of this Investigation, the following sections are included in the 'Conclusions' section:

- **Findings-** are statements of all significant conditions, events or circumstances in this Incident. The findings are significant steps in this Incident sequence but they are not always causal or indicate deficiencies.
- **Causes-** are actions, omissions, events, conditions, or a combination thereof, which led to this Incident.
- **Contributing factors-** are actions, omissions, events, conditions, or a combination thereof, which, if eliminated, avoided or absent, would have reduced the probability of the Incident occurring, or mitigated the severity of the consequences of the Incident. The identification of contributing factors does not imply the assignment of fault or the determination of administrative, civil or criminal liability.

### 3.2 Findings

- 3.2.1 The flight crewmembers were licensed and qualified for the flight in accordance with the existing requirements of the General Civil Aviation Authority (GCAA) of the United Arab Emirates (UAE).
- 3.2.2 The Aircraft was certified, equipped and maintained in accordance with the existing requirements of the GCAA.
- 3.2.3 The Aircraft was airworthy when dispatched for the flight.
- 3.2.4 Examination of the maintenance records did not reveal any evidence of pre-existing In-Flight Entertainment (IFE) system anomalies that could have contributed to the Incident.
- 3.2.5 The source of the emitted smoke was the inverter printed circuit board (PCB) that was heated by 'conduction' heat transfer from the fuse.
- 3.2.6 The fuse did not open the circuit quickly since its current rating was higher than required for the Video Display Unit (VDU) application.
- 3.2.7 The laboratory examination did not observe any similar failures involving similar fuses.
- 3.2.8 The failure was in two stages: the break in the secondary winding of the power supply transformer and then the fuse heat build-up.
- 3.2.9 Characteristics of the fuse material may have contributed to the heat build-up.
- 3.2.10 No traces of foreign particles were found inside the case of the VDU.
- 3.2.11 The defect history of the IFE system showed a number of screens had malfunctioned and the faults were cleared by resetting/rebooting.

3.2.12 The response of the flight crew and cabin crew to the emergency situation was in conformity with the operator's procedure.

3.2.13 The airport's standby response was in line with international standards.

### 3.3 Causes

The Air Accident Investigation Sector (AAIS) determines that the causes of the smoke that emitted from the VDU of seat 9A were:

3.3.1 Gasses emitted from the PCB of the VDU backlight inverter board.

3.3.2 Heat caused by increased current demand after the break in the secondary coil of the transformer followed by the failure of the primary side transistor components.

3.3.3 The failure of the fuse to open quickly and isolate the circuit due to its inappropriate rating related to the VDU application and possibly other reasons not determined by the Investigation.

### 3.4 Contributing Factors to the Incident

Contributing factor to the Incident was that the material of the fuse might have helped in transferring heat by 'conduction' between the fuse and the PCB of the backlight inverter board.

## 4. Safety Recommendations

### 4.1 General

The safety recommendations listed in this Report are proposed according to paragraph 6.8 of *Annex 13 to the Convention on International Civil Aviation*<sup>6</sup>, and are based on the conclusions listed in section 3 of this Report; the General Civil Aviation Authority (GCAA) expects that all safety issues identified by the Investigation are addressed by the receiving States and organizations.

### 4.2 Safety Actions Taken

Starting from May 2014, the Video Display Unit (VDU) manufacturer has ceased production of Liquid-Crystal Display (LCD) panels with Cold-Cathode Fluorescent (CCFL) backlight and the supporting inverter printed circuit board (PCB) has been discontinued in production of the 8.9-inch VDUs of the same affected P/N (100-2002-00X series). The manufacturer will produce VDUs with Light-Emitting Diode (LED) type backlight that does not utilize similar boards to the affected PCB.

For the in-service VDUs, and whenever the VDU is shipped to the manufacturer's facility for repair, the manufacturer will replace the existent fiberglass substrate material fuse with a ceramic body, suspended-in-air filament fuse. The modified VDUs will be recognized by the 'modification plate' located at the bottom of the VDU.

### 4.3 Final Report Safety Recommendations

The in-production and in-service modified Boeing 737 fleet of the operator is equipped with the same VDU part number, therefore the Air Accident Investigation Sector (AAIS) recommends that:

#### 4.3.1 The operator to-

##### **SR 43/2014**

Where feasible, and whenever the VDU is removed from the aircraft for any reason; the VDU to be shipped to the manufacturer for replacement of the fiberglass substrate material fuse by a ceramic body, suspended-in-air filament fuse.

---

<sup>6</sup> Paragraph 6.8 of *Annex 13 to the Convention on International Civil Aviation* states: "At any stage of the investigation of an accident or incident, the accident or incident investigation authority of the State conducting the investigation shall recommend in a dated transmittal correspondence to the appropriate authorities, including those in other States, any preventive action that it considers necessary to be taken promptly to enhance aviation safety."



#### **SR 44/2014**

For any future orders for any aircraft type equipped with similar VDU part number, to ensure that the VDU is of the modified LED backlight or modified open-to-air fuse standard.

#### **4.3.2 The General Civil Aviation Authority of the United Arab Emirates to-**

##### **SR 45/2014**

Ensure that any future Supplemental Type Certificate (STC) relevant to IFE installation on any of UAE-registered aircraft refers in the 'materials required' section to the modified VDU.

##### **SR 46/2014**

Disseminate the information included in this Report to all UAE operators for their proactive action in relation to any existing affected VDUs or for the addition of aircraft to their fleets equipped with similar part number VDUs.

**Air Accident Investigation Sector  
General Civil Aviation Authority  
The United Arab Emirates**