

ACCIDENT

Aircraft Type and Registration:	EC225 LP Super Puma, G-REDW
No & Type of Engines:	2 Turbomeca Makila 2A1 turboshaft engines
Year of Manufacture:	2009 (Serial no: 2734)
Date & Time (UTC):	10 May 2012 at 1114 hrs
Location:	20 nm east of Aberdeen
Type of Flight:	Commercial Air Transport (Passenger)
Persons on Board:	Crew - 2 Passengers - 12
Injuries:	Crew - None Passengers - 2 (Minor)
Nature of Damage:	Salt water immersion
Commander's Licence:	Airline Transport Pilot's Licence
Commander's Age:	40 years
Commander's Flying Experience:	3,060 hours (of which 2,740 hours were on type)
Information Source:	AAIB Field Investigation

This Special Bulletin contains information about the helicopter's main gearbox (MGB) lubrication system and the results of an investigation into the indication of a failure of the emergency lubrication system, after it was activated by the crew. It follows publication of two earlier Special Bulletins on this accident, AAIB Special Bulletins S2/2012 and S3/2012.

This was the first occasion that the EC225 LP MGB emergency lubrication system had been operated in-service. One Safety Recommendation is made.

The investigation into the failure of the bevel gear vertical shaft in the MGB continues.

This Special Bulletin contains facts which have been determined up to the time of issue. It is published to inform the aviation industry and the public of the general circumstances of accidents and serious incidents and should be regarded as tentative and subject to alteration or correction if additional evidence becomes available.

AAIB investigations are conducted in accordance with Annex 13 to the ICAO Convention on International Civil Aviation, EU Regulation No 996/2010 and The Civil Aviation (Investigation of Air Accidents and Incidents) Regulations 1996.

The sole objective of the investigation of an accident or incident under these Regulations is the prevention of future accidents and incidents. It is not the purpose of such an investigation to apportion blame or liability.

Accordingly, it is inappropriate that AAIB reports should be used to assign fault or blame or determine liability, since neither the investigation nor the reporting process has been undertaken for that purpose.

Extracts may be published without specific permission providing that the source is duly acknowledged, the material is reproduced accurately and is not used in a derogatory manner or in a misleading context.

Background

The helicopter was on a scheduled flight from Aberdeen Airport to the Maersk Resilient platform, in the North Sea, 150 nm east of Aberdeen. On board were two flight crew and twelve passengers. The helicopter was in the cruise at an altitude of 3,000 ft, 34 nm east of Aberdeen Airport, when the flight crew were presented with indications of low pressure in the MGB main and standby oil lubrication systems. The crew activated the MGB emergency lubrication system and, following a subsequent warning indicating failure of that system, carried out a controlled ditching into the sea.

All the passengers and crew evacuated the helicopter into a life raft and were subsequently rescued. Two passengers sustained minor injuries.

Aircraft information

MGB certification requirements

The EC225 LP was certified against the Joint Aviation Regulations (JAR) 29, which require the helicopter to continue safe flight, at prescribed torque and main rotor speeds, for at least 30 minutes following the loss of the MGB lubrication system. This is achieved on the EC225 LP by the use of an emergency lubrication system that uses a mixture of glycol and water (called Hydrosafe 620) which cools and lubricates the MGB.

MGB lubrication

The MGB fitted to the EC225 LP is of a largely similar design to the MGB fitted to the AS332 L2, but has a 15% greater torque capability. The MGB oil pumps (main and standby) are driven by two pinion gears located on the lower part of the bevel gear vertical shaft. The MGB normally contains 22 litres of oil.

The MGB lubrication system includes two mechanically-driven oil pumps and a crew-activated

emergency lubrication system (see Figure 1). The latter comprises: a bleed air supply from the left engine, a Hydrosafe 620 supply from an 11 litre reservoir, a series of small pipes around and inside the MGB, to deliver the Hydrosafe 620 in a spray, and monitoring and command systems on a dedicated Printed Circuit Board (PCB).

There is a vent on the side of the MGB through which Hydrosafe 620 mist, and potentially MGB oil, can pass.

When the emergency lubrication system is activated an electro-valve, called the P2.4 valve, opens and bleed air from the left engine enters the system, after passing through an air heat-exchanger. At the same time, an electric pump supplies Hydrosafe 620 from the reservoir. There are two similar sensors that monitor the pressure in the Hydrosafe 620 pipes and bleed air lines; these sensors are mounted on the MGB. A MGB EMLUB caption will illuminate if low pressure is detected in either the Hydrosafe 620 pipes or the bleed air lines. This warning is inhibited for approximately 30 seconds after the system is activated, to allow the system to reach a steady state.

The low pressure signal is generated by either the bleed air or Hydrosafe 620 pressure sensors if the pressure does not exceed a specified pressure value, p_{on} , when the system is activated, or the pressure subsequently falls below a specified pressure, p_{off} .

The specified range for p_{on} for the bleed air pressure sensor is between 0.6 and 1.0 bar (relative to ambient).

Using engine data, the bleed air from the left engine at the time of the accident would have entered the bleed air line at approximately 2.3 bar (absolute). This equated to around 1.4 bar (relative) due to the ambient pressure at an altitude of 3,000 ft.

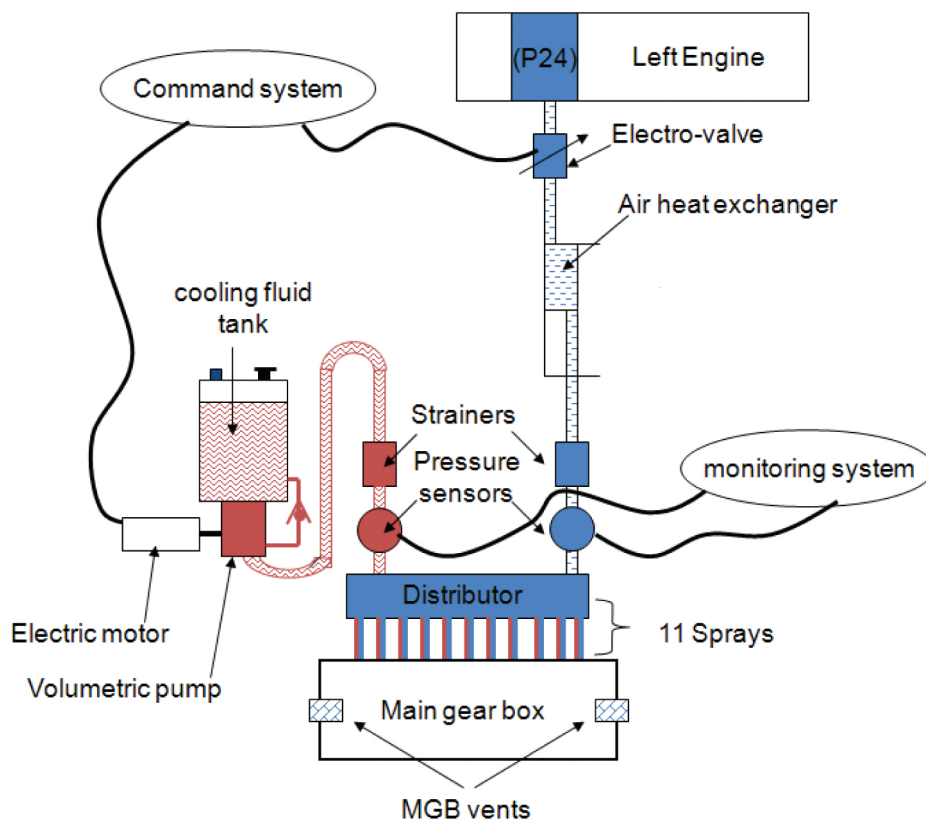

Figure 1

Schematic of the Emergency Lubrication System

Emergency lubrication system certification tests

The emergency lubrication system was certificated by the European Aviation Safety Agency (EASA). Certification included a test on a ground rig in which the oil was drained from a MGB and bleed air and Hydrosafe 620 were sprayed into the gearbox. The test demonstrated that there was no significant damage to the MGB after over 30 minutes of operation. Although the emergency lubrication sub-systems were tested individually, no test was carried out on the complete system, either on a test rig or installed on the helicopter type.

Emergency lubrication system investigation

Early in the investigation, it was established that the bevel gear vertical shaft in the MGB had failed, which

had interrupted the drive to both oil pumps. As a result of this failure and the loss of MGB oil pressure, the crew activated the emergency lubrication system. From the Cockpit Voice Recorder (CVR), it was determined that the MGB EMLUB caption illuminated 32 seconds after the crew activated the emergency lubrication system, and the time from activation to the failure of electrical power, after the aircraft ditched, was approximately 7½ minutes.

Hydrosafe 620 system

No evidence of any leaks in the Hydrosafe 620 system was found. The MGB sump was drained and was found to contain approximately 17 litres of liquid, of which approximately 1.5 litres was Hydrosafe 620, which is denser and of a different colour to the MGB oil. During a strip examination, evidence of glycol

was found throughout the MGB casing and on all the gears and bearings. There was no visual evidence of heat distress or damage to any of the components in the MGB.

The amount of fluid remaining in the Hydrosafe 620 reservoir was 7.8 litres, which, given that the reservoir holds 11 litres, would indicate that approximately 3.2 litres were used while the system was operating, if the reservoir was full. Using nominal flow rates for the pump, approximately 2.8 litres of Hydrosafe 620 would be used during 7½ minutes of system operation. Hence, there is evidence that the Hydrosafe 620 pump was operating normally from the time the system was activated until the aircraft ditched, when electrical power ceased.

If the MGB contained 22 litres of oil prior to the accident and approximately 3 litres of Hydrosafe 620 was sprayed into the MGB, then about 8 litres (25 minus 17) of fluid was probably lost through the vent. This would have been a combination of MGB oil and Hydrosafe 620 and, given that the latter comprises glycol and water, some of this was probably lost as water vapour.

Bleed air system

The connections for the components in the bleed air circuit were checked and appeared normal. No evidence of any leaks in the bleed air pipes was found, and pressure tests on the bleed air pipes and the heat exchanger revealed nothing abnormal. It was considered that it was unlikely that there were any leaks in the bleed air system.

The electrically operated P2.4 valve (which, when open, permits the flow of bleed air into the emergency lubrication system) was tested back-to-back with a new

valve. The tests were made at a range of flow rates and pressures. Whilst the P2.4 valve was found to remain partially open when no pressure was applied, it performed in a similar way to the new valve at the representative flow rates and pressures. It was concluded that the valve was not a factor in the indication of failure of the system. The pressure loss across the P2.4 valve was measured at around 0.02 bar.

The bleed air heat-exchanger from G-REDW was tested back-to-back with a new unit, at a range of pressures and flow rates, and was found to perform in a similar manner to the new unit. The pressure loss across the heat-exchanger from G-REDW, at conditions that the manufacture believed were similar to those at the time of the accident, was approximately 0.3 bar. However, it was not possible to determine accurately the flow rate for the bleed air at the time of the accident and the loss could have been over 0.6 bar. Hence, there is a significant error margin in the estimate for the pressure loss across the air heat-exchanger.

Printed circuit board

The PCB, which controls and monitors the emergency lubrication system, was functionally tested and operated in accordance with the factory inspection test. The time delay, during which a failure warning is inhibited, was measured at 32 seconds. This was the same as the period of time between the crew's activation of the system and the illumination of the MGB EMLUB caption.

Bleed air and glycol pressure sensors

Both sensors were tested at the equipment manufacturer where the acceptance tests were originally carried out. Both sensors conformed to their respective acceptance tests. For the bleed air pressure sensor, p_{on} was measured at 0.68 bar.

Wiring for the emergency lubrication system

The wiring on the helicopter for the emergency lubrication system was checked as thoroughly as practicable. The continuity and insulation were found to be satisfactory.

Analysis

The evidence indicates that the emergency lubrication system had activated and remained operating for the remainder of the flight. Thus the system had given the crew a false warning of system failure. This warning resulted in the crew ditching the helicopter in the sea.

From the CVR, it was determined that the MGB EMLUB caption illuminated 32 seconds after the emergency lubrication system was activated by the crew. The time delay during which the warning is inhibited on the PCB was also measured at 32 seconds. As far as practicable, all the components of the emergency lubrication system were tested and nothing abnormal was found. The quantity of Hydrosafe 620 that remained in the reservoir and the quantity found in the MGB sump indicated that the Hydrosafe 620 was delivered correctly. Given that the emergency lubrication system appears to have cooled and lubricated the MGB successfully, from its activation until the aircraft ditched, it was concluded that its monitoring system gave a false indication of failure.

When the bleed air pressure sensor was tested, p_{on} was measured at 0.68 bar. The pressure at the input to the bleed air line would have been about 1.4 bar (relative), with the loss across the air heat-exchanger

around 0.3 bar, but this could have been greater. There would also have been losses in other parts of the system upstream of the pressure sensor. The margins are small and the possible error bands are significant. It is possible, therefore, that the bleed air pressure sensor on G-REDW triggered the MGB EMLUB caption.

More importantly, the upper end of the specification for the bleed air pressure to trigger a low pressure input to the monitoring system is 1.0 bar (relative). Therefore, it was concluded that a bleed air pressure sensor at the top end of the specified tolerance could generate an MGB EMLUB caption, even though all the parts of the emergency lubrication system are operating within their specifications.

Safety Recommendation

This was the first time the MGB emergency lubrication system on the EC225 LP had been activated operationally and it has been determined that a pressure sensor that is within tolerance could generate an MGB EMLUB caption, even though the system is cooling and lubricating the MGB successfully. Therefore, the following Safety Recommendation is made:

Safety Recommendation 2012-034

It is recommended that the European Aviation Safety Agency requires Eurocopter to review the design of the main gearbox emergency lubrication system on the EC225 LP Super Puma to ensure that the system will provide the crew with an accurate indication of its status when activated.

Published 17 October 2012